



Radiation Protection

A comprehensive array of advanced, innovative, and integrated personal radiation protection solutions designed to meet the diverse needs of medical professionals, including high-quality, ergonomic aprons, specialized eyewear, gloves and shielding solutions.

your single source supplier™





Trusted provider to medical imaging professionals since 2000

Imaging Solutions is celebrating over 25 years as a trusted provider of market-leading medical imaging equipment and accessories. With an unwavering commitment to innovation, quality, and service, we continue to deliver cutting-edge solutions that empower healthcare professionals worldwide.

25
years

your single source supplier™

Table of Contents

Protective Aprons	4
Front and Back Protection - Two Piece	8
Front Panel Protection - One Piece	11
Front and Back Protection - One Piece	14
Express Range	16
Sizing	18
Fabrics, Trims and Colours	22
Protective Core Material	26
Accessories	28
Storage and Care	31
Patient Protection	35
Fleet Management	38
Protective Gloves	40
Scatter Drapes	44
Protective Eyewear	46
Mobile Shields	60
Undertable Shields	72
Overtable Shields	88
Protective Windows	94
Education	104

Regulatory Notice

Imaging Solutions operates in Australia, New Zealand, the United States, the European Union, and engages with resellers and distributors globally. Product availability in this catalogue may vary by region and is subject to local regulatory classifications and approvals. Certain products may only be available in jurisdictions where they have been registered or authorized by the relevant regulatory authorities. For details on product availability in your region, please contact Imaging Solutions.



Manufactured to exceptionally high standards, RADsafe® aprons are available in a selection of ergonomic and gender-specific designs. Available in a full range of sizes to maximise flexibility and comfort.

RADsafe® apron can be safely and comfortably worn more frequently, or for extended periods of time. Users can choose from a select range of protective core materials and lead equivalency options for reliable protection without compromise. To complement our protective apparel range, RADsafe provides a variety of online tracking, reporting and management products to ensure your new product has long-lasting support.

Quality & *Protection* without Compromise

Our commitment is to deliver 'Optimum Quality, Compliance, and Protection you can depend on.'

RADarmor

RADarmor is a chemical that forms an antimicrobial coating that bonds to surfaces and protects against many pathogens, including bacteria and mould.

RADlab®

RADlab is an established radiation attenuation testing lab for the exclusive purpose of supporting hospitals and medical imaging practices.

RADdrape®

RADdrape Anti-scatter disposable sterile drapes are designed to prevent scatter radiation at the source, creating a scatter-free zone by reducing harmful ionizing radiation exposure.

RADprotect

RADprotect is a range of recyclable plastic splash drapes designed to fit popular models of personal radiation shields.

RADeco®

RADeco by Imaging Solutions endeavours to support customers in disposing potentially harmful radiation protective materials that may contain lead and other heavy metals.

RADshield

RADshield is a series of personal mobile portable shields for use in X-ray and radiation rich medical environments.

RADfresh®

RADsafe's exclusive RADfresh® Apron Refresher is a purpose-made cleaning solution for personal radiation protection apparel of all types.

RADstore®

Quality, effective, and innovative storage solutions for personal radiation protective apparel.

RADview

RADview is radiation protective glass and acrylic used in medical fields including dental, CT, and X-ray.

RADtrack®

RADtrack™ is a personal radiation protection apparel tracking, reporting, and management system suitable for use by organisations of all sizes.



RADsafe® Apron Ordering Guide

1. Apron Style

Page 8



2. Gender / Size

Page 18



3. Customisations or Embroidery

Page 21

Embroidery -
Block / Script



Embroidery -
Custom Logo



Extra Length -
Skirt and Vest Adjustments



4. Trims and Fabric Options

Page 23

AEGIS -
Premium Range



Nylon -
Standard Range



Ripstop -
Reinforced Nylon



Designer -
Foundation Range



Designer -
Select Range



Designer -
Exclusive Range

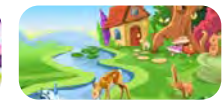

5. Protection (RADcore™)

Page 26

RADcore™

Lead Equivalencies -
0.25 / 0.35 / 0.50 / 0.75 / 1.00/ etc...

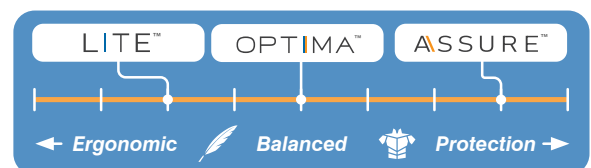

6. Accessories

Page 30

Smart Cap



Shoulder Protection



Shin Guard Protection



Thyroid Covers





Why Choose RADsafe?

1. Advanced Design



RADsafe's unique garment designs represent a perfect balance between ergonomics and radiation protection. This balance has been achieved by combining human design standards, sizing standards, and population datasets with leading international standards from IEC, DIN, and ASTM. Our designs are regularly reviewed and updated as part of our commitment to continuous improvement, based on customer feedback, internal innovation, and standards review. At the heart of our design philosophy is the wearer's quality of working life, and we strive to optimize comfort and ergonomics without compromising on protection.

2. Durability that you Can Depend On



RADsafe's garments are built to the highest standards, using the latest assistive technologies and specialized machinery, refined stitching techniques, and high-quality raw materials. Each garment is guaranteed to meet specifications and provide long-lasting durability. Our garments are designed with your needs in mind, incorporating features that address common market concerns. For example, our textiles are carefully chosen to provide the right balance of flexibility and density to reduce tearing and fraying without hindering the garment's use. We use automated laser-guided cutting machines to ensure consistent sizing and quality, and our stitching techniques reinforce high-stress points like pocket corners and hanging straps for added durability. With RADsafe, you can trust that you are getting a high-quality garment that will provide reliable protection.

3. Sizing that Makes Sense



RADsafe's sizing options and range are based on real-world population data, rather than industry or market representations, to ensure that our medium size is representative of the median wearer. We understand that one size does not fit all, and one design does not fit all, so we have designed each size option against its own individual specification. This ensures that each size provides optimal coverage and performance for the wearer, while also maintaining a consistency across the sizing range. At RADsafe, we are committed to providing our customers with the protection they need, in the sizes that fit them best.

4. Fully Customisable



At RADsafe, we offer fully customizable personal radiation protection to meet your specific needs. Our male and female specific designs come in a range of sizes, which can also be tailored to ensure a perfect fit and optimal protection. We offer a wide range of lead-free protective core materials ranging from highly protective to highly ergonomic, low-lead options are also available. Plus, our selection of fabrics, patterns, and trims allows you to create a look that is both stylish and protective. This allows you to choose the level of protection and comfort that is right for you.



5. Arrives Faster



RADsafe personal radiation protection is manufactured in a highly optimized and streamlined production process, ensuring that the majority of orders are dispatched within 2-3 weeks. For those with urgent requirements explore our Express range which can be dispatched immediately from stock or within 5 days. This allows us to provide our customers with the protection they need, when they need it. Whether you need your order quickly or have a more flexible timeline, RADsafe has a solution to meet your needs.

6. Asset Tracking with RADtrack™



As a RADsafe customer, you have access to our complementary RADtrack™ system. This makes it easy to integrate your RADsafe personal radiation protection and manage the risk associated with regular screening. RADtrack™ is simple to use, easy to access, and can save your department or facility significant time and money.

7. Independently and Internally Tested with RADlab



At RADsafe, we are committed to providing our customers with the protection they expect and deserve. Our radiation attenuation materials, or “core” materials, are certified to leading international standards by recognized independent laboratories. To ensure that our post-production materials perform similar to the samples used in formal certification processes, we also perform random attenuation testing. This helps us ensure that our products are consistently high-quality and effective at protecting against radiation exposure.

8. Quality Management Built-In



Imaging Solutions is dedicated to continually improving our business practices and performance. To support this goal, we have adopted leading quality management principals to provide a standardized framework for sustainability and process/business improvements. Our quality management systems are certified to ISO 9001 - “Quality Management Systems” and ISO 13485 - “Quality Management System for Medical Devices.” This commitment to quality helps us ensure that our customers receive the highest-quality products and services.

9. Two Year Warranty as Standard



Our standard two-year warranty on RADsafe personal radiation protective aprons demonstrates our dedication to high-quality workmanship and reliable materials, giving you confidence and peace of mind. With RADsafe, you can trust that you are getting a top-quality product that you can rely on for years to come.

10. World Class Customer Service



Draw on the experience and expertise of our world-class team. Our customer service team is the best in the business and can assist you with any situation you may encounter. With their knowledge and expertise, you can trust that you will receive the highest level of support and guidance. Let our team help you find the right solution for your radiation protection needs.

11. Immerse yourself in the RADfamily



RADsafe personal radiation protection is just the beginning of the comprehensive radiation protection solution offered by Imaging Solutions. Continue your radiation protection journey with our many complimenting supplier partner products and our own RADdrape, RADfresh, RADstore, RADshield, and RADview, among others. With these products and services, you can be confident that you are receiving the best protection and support possible. Take the next step in your radiation protection journey with RADsafe and our partner products and services.



Vest and Skirt with Back Relief Belt

The RADsafe Back Relief Vest and Skirt is our most popular full protective apron. It unites the ergonomic benefits of the original Vest and Skirt Apron with the comfort and weight distribution properties of our Back Relief Apron. The two-piece design allocates a relatively free upper body rotation, and the weight is split and distributed in two areas.

The vest contains a weight reduction belt which relocates the weight from the shoulder to lower back and the skirt includes a built-in elasticised belt for maximum comfort.

Fitting and storage time are critical in the medical industry, the application time is a standard 30 - 90 seconds. The apron is suited for long procedures to assist with shoulder and lumbar support. See the most common applications below.

Benefits

- Suited for long periods
- Shoulder support
- Lower lumbar support

Application

- Catheter laboratory
- Endoscopy
- Operating theatres
- Hybrid laboratory

Size Tolerance

- Specific - Half a size +/-

Application Time

Standard (30 - 90 seconds)

Protection

Front and Back

Weight Ergonomics

3 points

(Shoulders, waist and hips)

Vest and Skirt with Back Relief Belt

RAD-AP-VS-BR



Vest and Skirt with Full Overlap and Back Relief Belt

The RADsafe Back Relief Vest and Skirt with Full Overlap combines the properties of the Vest and Skirt Back Relief Apron with the additional full overlap of the apron. The apron offers comfort and weight distribution properties from the back relief belt. The two-piece design allocates a relatively free upper body rotation, and the weight is split and distributed in two areas.

Fitting and storage time are critical in the medical industry, the application time is a standard 30 - 90 seconds. The apron is suited for long procedures to assist with shoulder and lumbar support. See the most common applications below.

Benefits

- Suited for long periods
- Shoulder support
- Lower lumbar support

Application

- Catheter laboratory
- Endoscopy
- Operating theatres
- Hybrid laboratory

Size Tolerance

- Exact - No size tolerance

Application Time

Standard (30 - 90 seconds)

Protection

Front and Back

Weight Ergonomics

3 points

(Shoulders, waist and hips)

Vest and Skirt with Full Overlap and Back Relief Belt

RAD-AP-VS-BR-FO





Vest and Skirt Apron

The RADsafe Vest & Skirt Apron is our standard two-piece full apron. It provides front and back protection, and the two-piece design makes it simpler to rotate the upper body independently from the legs. The weight is distributed across the body equally, with the vest for the upper body and the skirt supporting from the waist down. The skirt contains a built-in elasticised belt for comfort.

The Vest and Skirt Apron offers excellent lumbar support particularly during extended procedures. The apron's two essential protective contact points are the shoulders and hips. The Vest and Skirt is a specific fit. See the most common applications below.

Benefits

- Suited for long periods
- Skirt and belt lumbar support

Application

- Catheter laboratory
- Endoscopy
- Operating theatres
- Hybrid laboratory

Size Tolerance

- Specific - Half a size +/-

Application Time

Standard (30 - 90 seconds)

Protection

Front and Back

Weight Ergonomics

2 points
(Shoulders and hips)

Vest and Skirt Apron

RAD-AP-VS



Vest and Skirt Apron with Full Overlap

The RADsafe Vest & Skirt Apron with Full Overlap Vest is a variation of our Vest and Skirt standard two-piece full apron with the benefit of the overlap vest. It provides front and back protection, and the two-piece design makes it simpler to rotate the upper body independently from the legs. The weight is distributed across the body equally, with the vest for the upper body and the skirt supporting from the waist down. The skirt contains a built-in elasticised belt for comfort.

The Vest & Skirt Apron with Full Overlap Vest offers excellent lumbar support particularly during extended procedures. The apron's two essential protective contact points are the shoulders and hips and it is a specific fit. See the most common applications below.

Benefits

- Suited for long periods
- Skirt and belt lumbar support

Application

- Catheter laboratory
- Endoscopy
- Operating theatres
- Hybrid laboratory

Size Tolerance

- Exact - No size tolerance

Application Time

Standard (30 - 90 seconds)

Protection

Front and Back

Weight Ergonomics

2 points
(Shoulders and hips)

Vest and Skirt Apron with Full Overlap

RAD-AP-VS-FO



Please read the 'Overlap Explained' article on page 104 of this catalogue to assist with your selection.



Vest and Skirt with Reverse Vest

The RADsafe Reverse Vest & Skirt Apron is a mobility focused front and rear protection apron. By removing the front overlap from the original Vest & Skirt Apron, the Reverse Vest & Skirt Apron alleviates any vertical rigidity, allowing for more flexible range of motion. The weight is distributed across the body evenly with the vest on the upper body and the skirt supporting from the waist.

The Reverse Vest and Skirt Apron is a flexible fit. The wearer can fit in a variety of sizes, for example it can accommodate a size range of small – medium. See the most common applications below.

Benefits

- Flexible range of motion

Application

- Catheter laboratory
- Endoscopy
- Operating theatres
- Hybrid laboratory

Size Tolerance

- Flexible - One size +/-

Application Time

High (60 - 120 Seconds)

Protection

Front and Back

Weight Ergonomics

3 points of distribution
(Shoulders, waist and hips)

Vest and Skirt with Reverse Vest

RAD-AP-VS-RV



RADsafe Vest and Skirt with Comfortwear Vest

The RADsafe Vest & Skirt Comfortwear Apron shares the same qualities as the Comfortwear Apron, with the key difference being that it's a two-piece apron. The skirt also offers rear protection. The apron has been designed to extend the weight of the garment across the back, therefore reducing shoulder fatigue. The skirt holds its weight on the hips, further eliminating back strain.

The elasticised back and hook-and-loop adjustable straps makes the Vest and Skirt Comfortwear Apron one of the most comfortable aprons available.

The Vest and Skirt Comfortwear Apron is a flexible fit. The wearer can fit in a variety of sizes, for example the apron can accommodate a size range of small – medium. See the most common applications below.

Benefits

- Flexible range of motion

Application

- Catheter laboratory
- Endoscopy
- Operating theatres
- Hybrid laboratory

Size Tolerance

- Flexible - One size +/-

Application Time

High (60 - 120 Seconds)

Protection

Front and Back

Weight Ergonomics

3 points of distribution
(Shoulders, waist and hips)

Vest and Skirt with Comfortwear Vest

RAD-AP-VS-FB



Frontal Apron with Comfortwear

The RADsafe Comfortwear Apron has been designed to spread the weight of the garment across the wearer's back, therefore reducing shoulder fatigue. The elasticised back and hook-and-loop adjustable straps make the Comfortwear Apron one of the most comfortable front-only aprons available.

At RADsafe we strive to make our protective aprons simple to apply and remove. Fitting and storage time are critical in the medical industry, the application time is a quick 10 - 30 seconds. The Comfortwear Apron is ideal for use during short periods of time. See the most common applications below.

Benefits

- Suited for short periods
- Ideal for quick application

Application

- Radiology
- Minor surgery
- Vets

Size Tolerance

- Specific - Half a size +/-

Application Time

Quick (10-30 Seconds)

Protection

Front Only

Weight Ergonomics

2 points
(Shoulders and waist)

Frontal Apron with Comfortwear

RAD-AP-FB



Frontal Apron with Back Relief Belt

The RADsafe Back Relief Apron features an elasticised belt which significantly repositions the apron's weight from the shoulders to the lower back. The Back Relief Apron is our most ergonomic front-only apron. The wide elastic belt spreads the weight across a wide surface on the wearer's back minimising the pressure at a single point for a more comfortable wear.

The Back Relief Apron is a flexible fit and is best used during short periods of time.

Benefits

- Suited for short periods, especially minor surgeries

Application

- Radiology
- Minor surgery
- Vets

Size Tolerance

- Flexible - One size +/-

Application Time

Quick (10-30 Seconds)

Protection

Front Only

Weight Ergonomics

2 points
(Shoulders and waist)

Frontal Apron with Back Relief Belt

RAD-AP-BR



Frontal Apron with Buckle

The RADsafe Buckle Apron utilises a buckle fastener around the waist of the wearer. It is a front-only apron with waist straps that can be adjusted for a tighter or looser fit depending on the wearer's preference. The Buckle Apron is a flexible fit and is suited for short procedures.

Fitting and storage time are critical in the medical industry. The application time for the Buckle Apron is a quick 10-30 seconds. See the most common applications below.

Benefits

- Suited for short periods, especially minor surgeries

Application

- Radiology
- Minor surgery
- Vets

Size Tolerance

- Flexible - One size +/-

Application Time

Quick (10-30 Seconds)

Protection

Front Only

Weight Ergonomics

2 points
(Shoulders and waist)

Frontal Apron with Buckle

RAD-AP-BA



Frontal Apron with Easy Tie

The RADsafe Tie Apron is our simplest front-only apron design, featuring a waist strap that can be tied to suit the wearer.

The Tie Apron is a flexible fit and is suited for short procedures.

Fitting and storage time are critical in the medical industry. The application time is a quick 10-30 seconds. See the most common applications below.

Benefits

- Suited for short periods, especially minor surgeries

Application

- Radiology
- Minor surgery
- Vets

Size Tolerance

- Flexible - One size +/-

Application Time

Quick (10-30 Seconds)

Protection

Front Only

Weight Ergonomics

2 points
(Shoulders and waist)

Frontal Apron with Easy Tie

RAD-AP-TA



Front Apron with Surgical Drop-Away

The Surgical Drop-Away is a front-only apron and is designed to be removed as quickly as possible after a surgical procedure. Detaching the two straps on the sides is all it takes for the apron to come free. This apron features shoulder straps which allows a second person to hold the apron as it is quickly removed.

The Surgical Drop-Away Apron is a flexible fit and is suited for short periods, especially minor surgeries

See the most common applications below.

Benefits

- Suited for short periods, especially minor surgeries

Application

- Radiology
- Minor surgery
- Vets

Size Tolerance

- Flexible - One size +/-

Application Time

Quick (10-30 Seconds)

Protection

Front Only

Weight Ergonomics

2 points
(Shoulders and waist)

Surgical Drop-Away Apron

RAD-AP-SD



Urology Apron

The RADsafe Urology Apron is a front-only apron designed to allow maximum comfort and protection while in a seated position. The three-flap design makes it perfect during urological procedures.

The Urology Apron is a flexible fit. At RADsafe we strive to make our protective aprons simple to apply and remove. The application time is a quick 10-30 seconds.

Benefits

- Suited for urological surgeries or procedures
- Maximum comfort and protection when in seated position

Application

- Urological procedures

Size Tolerance

- Flexible - One size +/-

Application Time

Quick (10-30 Seconds)

Protection

Front Only

Weight Ergonomics

2 points
(Shoulders and waist)

Urology Apron

RAD-AP-UA



Wrap-Around with Back Relief Belt

The RADsafe Wrap-Around Back Relief Apron is a full, single-piece apron which fastens with buckle across the front panel. This apron also features a large, elasticised back support belt to relocate the weight from the shoulders to the back making it more ergonomic and comfortable if required for long periods of time.

The Wrap-Around Back Relief Apron offers an easily accessible flexible fit for quick application during short procedures. At RADsafe we strive to make our protective aprons simple to apply and remove. The Wrap Around Back Relief Apron has the fastest application, removal, and storage time of all our protective aprons, the application time is a quick 10 - 30 seconds. See the most common applications below.

Benefits

- Quick Application for Emergency Department
- Suitable for short periods
- Easily accessible

Application

- Emergency Department
- Minor procedures

Size Tolerance

- Flexible - One size +/-

Application Time

Quick (10-30 Seconds)

Protection

0.25, 0.35 and 0.50mmPb
Non Lead/Low Lead/Lead

Weight Ergonomics

2 points
(Shoulders and waist)

[Wrap-Around Back Support Apron](#)

RAD-AP-WA-BR



Wrap-Around with Full Overlap and Back Relief Belt

The RADsafe® Wrap-Around with Full Overlap and Back Relief Belt combines the properties of the Wrap-Around Back Relief Apron with the additional full overlap of the apron. The apron is a full, single-piece apron which fastens with buckles across the front panel. This apron also features a large, elasticised back support belt to relocate the weight from the shoulders to the back making it more ergonomic and comfortable if required for long periods of time.

The Wrap-Around Back Relief Apron offers an easily accessible flexible fit for quick application during short procedures. The Wrap Around Back Relief Apron has the fastest application, removal, and storage time of all our protective aprons, in a quick 10 - 30 seconds. See the most common applications below.

Benefits

- Quick Application for Emergency Department
- Suitable for short periods
- Easily accessible

Application

- Emergency Department
- Minor procedures

Size Tolerance

- Exact - No size tolerance

Application Time

Quick (10-30 Seconds)

Protection

0.25, 0.35 and 0.50mmPb
Non Lead/Low Lead/Lead

Weight Ergonomics

2 points
(Shoulders and waist)

[Wrap-Around Back Support Apron](#)

RAD-AP-WA-BR-FO





Smock Apron

The RADsafe Smock Apron is a full apron which fastens along the two sides with hook-and-loop straps. The apron's vital protective contact point is the shoulders.

The Smock Apron is a flexible fit. Fitting and storage time are critical in the medical industry. The application time is a quick 10-30 seconds. See the most common applications below.

Benefits

- Quick Application for emergency department
- Suitable for short periods
- Ideal for patient protection

Application

- Emergency Department
- Radiology
- Patient Protection

Size Tolerance

- Flexible - One size +/-

Application Time

Quick (10-30 Seconds)

Protection

0.25, 0.35 and 0.50mmPb
Non Lead/Low Lead/Lead

Weight Ergonomics

1 point (Shoulders)

Smock Apron

RAD-AP-SM



Maternity Apron

The RADsafe Maternity Apron is designed for pregnant wearers. It features a waist strap which can be tied at the front for maximum flexibility. This apron comes with a half apron which is worn underneath the front flap for additional protection.

The apron's three vital protective contact points are the shoulders, underarm and waist. The Maternity Apron is a flexible fit.

At RADsafe we strive to make our protective aprons simple to apply and remove. Fitting and storage time are critical in the medical industry. The application time is a standard 30 - 90 seconds. See the most common applications below.

Benefits

- Ideal for all procedures
- Suitable for long or short periods
- Includes half apron

Application

- All departments including:
Operating Theatres
Catheter Laboratory

Size Tolerance

- Flexible - One size +/-

Application Time

Standard (30 - 90 Seconds)

Protection

0.25, 0.35 and 0.50mmPb
Non Lead/Low Lead/Lead

Weight Ergonomics

3 points (Shoulders, underarm and waist)

Maternity Apron

RAD-AP-MA

Express Personal Radiation Protection



The Express range by RADsafe, is an array of in-stock radiation protection apparel that offers accelerated shipping. The combination of our in-stock inventory and global outreach allows us to swiftly ship the products that you need, when you need them!

The three models that we have selected to champion this range are the popular Vest & Skirt Back Relief, Wrap Around Back Relief, and the Comfortwear apron. Each of these Express models are exclusively offered in our AEGIS premium fabric for added comfort and protection.

Express Thyroid Collars Options



Visor Straight Contoured

The RADsafe® Thyroid Collar is an essential accessory included in the full body X-Ray radiation protection offering. The protective thyroid collars are available in three distinct shapes, Contoured, Straight and Visor to accommodate preference and cover entire thyroid area.

X-Small: 30cm - 38cm (11.8" - 15.0")
 Regular: 36cm - 44cm (14.2" - 17.3")
 X-Large: 42cm - 50cm (16.5" - 19.7")
 (neck circumference)

Express Thyroid Ordering Guide

RAD-AP- TCCT - U OM 0 - NLB61 - 50 - 02

Model	Gender	Size	Length	Core	mmPb LE	Colour
TCCT	U	OS	0	NLB61	50	01
TCST		OM			30	02
TCVS		OL				cont ...

Model	Description
TCCT	Thyroid Collar Contoured
TCST	Thyroid Collar Straight
TCVS	Thyroid Collar Visor

Core	Description
NLB61	Non-Lead Bi-layer 60-110 kV

mmPb LE	Description
50	0.50mmPb LE
30	0.35mmPb LE

AEGIS - Premium Fabric

Introducing the softest, most comfortable protective apron fabric on the market: **Aegis**. Exclusive to Imaging Solutions, this premium fabric is made with bacterial-resistant qualities that make it ideal for use in healthcare environments. Additionally, it is waterproof and flame resistant. Its abrasion resistance ensures that it can withstand the demands of frequent use, while its soft touch fabric provides a snug and secure fit for maximum comfort. Treat yourself and your apron with Aegis fabric.

- Abrasion resistant results in an apparel item that is tougher and lasts longer.
- Waterproof to not only protect core protective materials but also make periodic cleaning quick and easy.
- Made with bacterial resistant qualities that make the fabric ideal for healthcare environments.
- The conforming fabric is designed to fit comfortably and securely, providing maximum comfort during wear.

01 Black	06 Sky Blue
02 Navy	07 Denim
03 Red	08 Purple
04 Olive	09 Tiger Lily
05 Grey	10 Geranium

Express Apron Options



Vest and Skirt Back Relief

A two-piece design allowing free upper body rotation. Weight is distributed in two pieces with a large elastic strap, relocating weight from shoulder to back. The skirt has a built-in elasticised belt.



Wrap Around Back Relief

A full single-piece apron, fastening with buckles across the front panel with an elasticised back support belt to relocate weight from shoulders to back for comfort when wearing over long periods of time.



Comfortwear

Designed to spread the garment weight evenly across wearer's back, reducing shoulder fatigue. An elasticised back and hook-and-loop adjustable straps makes this apron a very comfortable front only apron.

Express Apron Ordering Guide

RAD-AP- VSBR - M 0L 0 - NLB61 - 32 - 04

Model	Gender	Size	Length	Core	mmPb LE	Colour
VSBR	M	2S	S*	NLB61	52	01
VEBR	F	1S	0		32	02
SK00	U*	0S	L*		50	03
WABR		0M			30	04
FB00		0L				05
		1L				06
		2L				07
						cont ...

Model	Description
VSBR	Vest and Skirt Back Relief
VEBR	Vest with Back Relief
SK00	Skirt Only
WABR	Wrap Around Back Relief
FB00	Comfortwear

Core	Description
NLB61	Non-Lead Bi-layer 60-110 kV

mmPb LE	Description
52	0.50mmPb LE Front / 0.25mmPb LE Back
32	0.35mmPb LE Front / 0.25mmPb LE Back
50	0.50mmPb LE Front
30	0.35mmPb LE Front

* Universal sizes and additional length options coming soon.

** Express aprons pictured with thyroid collar available separately, see below for ordering.

Apron Sizing Chart

Male Sizing



Male Apron Sizing

Version 2104

Size	Chest (A)		Waist (B)		Hips (C)		Vest Length(D)		Skirt Length (E)		Full Length (F)	
	cm	in	cm	in	cm	in	cm	in	cm	in	cm	in
XX-Small	80-88	31-35	66-74	26-29	81-87	32-34	60	24	55	22	95	37
X-Small	88-96	35-38	74-82	29-32	87-93	34-37	62	24	57	22	98	39
Small	96-104	38-41	82-90	32-35	93-99	37-39	63	25	58	23	100	39
Medium	104-112	41-44	90-98	35-39	99-105	39-41	65	26	60	24	104	41
Large	112-120	44-47	98-106	39-42	104-112	41-44	67	26	62	24	108	43
X-Large	120-128	47-50	106-114	42-45	112-120	44-47	69	27	64	25	111	44
XX-Large	128-136	50-53	114-122	45-48	120-128	47-50	71	28	66	26	115	45



Tool Assisted Measuring

Save time by visiting our website at www.imgsol.com/get-measured to utilise our selected tool assisted measuring service.

Tailored and Custom Sizes Available

Female Sizing



Female Apron Sizing

Version 2104

Size	Chest (A)		Waist (B)		Hips (C)		Vest Length(D)		Skirt Length (E)		Full Length (F)	
	cm	in	cm	in	cm	in	cm	in	cm	in	cm	in
XX-Small	74-82	29-32	54-62	21-24	74-82	29-32	52	20	52	20	90	35
X-Small	82-90	32-35	62-70	24-28	82-90	32-35	54	21	54	21	90	35
Small	90-98	35-39	70-78	28-31	90-98	35-39	55	22	55	22	92	36
Medium	98-106	39-42	78-86	31-34	98-106	39-42	57	22	57	22	94	37
Large	106-114	42-45	85-95	33-37	106-114	42-45	59	23	59	23	98	39
X-Large	113-123	44-48	95-105	37-41	113-123	44-48	61	24	61	24	102	40
XX-Large	123-133	48-52	105-115	41-45	123-133	48-52	63	25	63	25	106	42



View Latest Sizing Information Online

<https://www.imgsol.com/sizing-and-fitting/>

Apron Fitting and Options

How to Measure for Correct Fit

Below is a basic step-by-step guide on how to measure someone for a correct fit of a radiation protective apron. On the next page we have also provided a size guide so you can use the measurements you take to determine the correct size.



Chest Measurement

Measure around the largest circumference of the chest / bust area, keeping the tape parallel to the floor and with the person's arms at their sides.



Waist Measurement

Measure around the smallest circumference of the torso. The waist level may dip in at the back.



Hips Measurement

Measure around the largest circumference of the hips and buttocks with the tape parallel to the floor; generally 20-23cm down from the waist measurement.



Front Apron Length Measurement

Measure from the top of the shoulder down over the chest / bust (nipple) to the desired length. Do not contour the tape measure in under the bust.



Vest Length Measurement

Measure from the top of the shoulder down over the chest / bust (nipple) to the desired length. Do not contour the tape measure in under the bust.



Skirt Length Measurement

Measure from the top of the pant line (waist) and over the outside of the hip down to the desired length.

Apron Customiser

The RADsafe online apron customiser tool provides wearers with a preview of exactly how their Personal Radiation Protection Apron will look before purchasing the garment.

With an array of standard and vibrant colours and patterns on offer for our Radiation Protection Aprons, there are fabric and trim options suitable for anyone. From basic standard branding colours to bright and cheery patterns to bring joy to patients and staff.

Visit www.imgsol.com to review your chosen patterns or fabrics on the apron model of your choice.

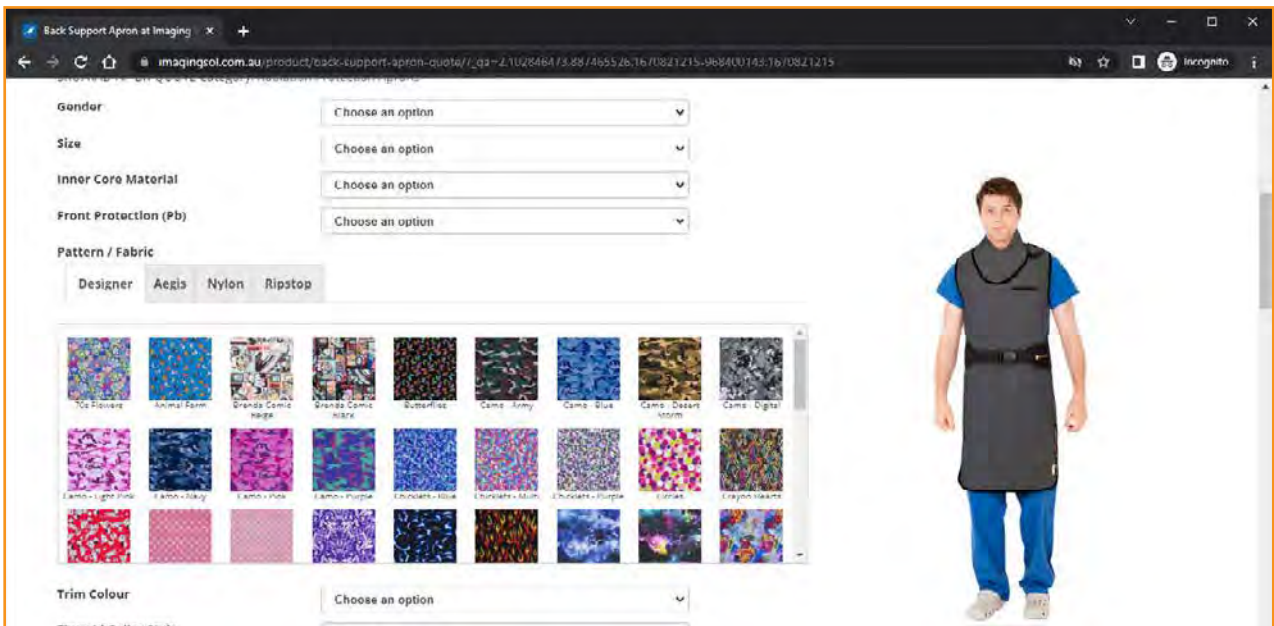

Apron Embroidery

We offer high-quality text and logo embroidery services for all aprons and accessories. Our embroidery enhances the professional appearance of your aprons and adds a personal touch that can distinguish your brand or business.

Why Choose Our Embroidery Services?

Quality and Durability: Our embroidery services use top-of-the-line threads and state-of-the-art equipment to ensure that your designs are visually appealing and durable, withstanding regular wear and cleaning.

Wide Range of Colors: We offer a diverse palette of thread colours that complement the trims of our aprons, allowing for both subtle tone-on-tone looks and bold contrasts.

Font Options

Block: A clean, modern font that offers excellent readability and a professional look.

Script: A stylish, cursive font that adds a touch of elegance and sophistication.

Block and Script Text



Fabric Colour and Pattern Options

Imaging Solutions offers a range of outer fabric options including standard colour / patterns, water-proof colours, exclusive patterns as well as a variety of premium colours / patterns and customer made fabrics available at an extra cost.

Trim Colours

Aqua		Orange	
Army Green		Purple	
Black		Red	
Brown		Rose	
Burgundy		Royal Blue	
Charcoal		Royal Purple	
Forest Green		Sky Blue	
Gold		Steel Blue	
Grey		Taupe	
Hot Pink		White	
Lime		Yellow	
Navy			

Inner Lining



Black Nylon Lining

Lightweight version of our exterior nylon allowing for improved fit feel and comfort against the body.



CoolGuard – Generation 1

Polyester/spandex combination with a moisture-wicking technology supporting better temperature regulation through the wicking of moisture from the body to the fast-drying fabric.



CoolGuard – Generation 2

Soft touch nylon and polyurethane coated combination, the nylon is a mid-weight two ply texture allowing improved breathability while the polyurethane coating provides moisture resistance barrier between the fabric and other layers of the apparel. Internal testing identified this fabric as providing greater levels of comfort and temperature regulation.



CoolGuard – Generation 3

Coming Soon – combination of generation one and generation two features with potential temperature distribution layers.

Or your choice of any exterior fabric

AEGIS - Premium Range

Introducing the softest, most comfortable protective apron fabric on the market: **Aegis**. Exclusive to Imaging Solutions, this premium fabric is made with bacterial-resistant qualities that make it ideal for use in healthcare environments. Additionally, it is waterproof and flame resistant. Its abrasion resistance ensures that it can withstand the demands of frequent use, while its soft touch fabric provides a snug and secure fit for maximum comfort. Treat yourself and your apron with Aegis fabric.



Made with bacterial resistant qualities that make the fabric ideal for healthcare environments.



Abrasion resistant results in an apparel item that is tougher and lasts longer.



The conforming fabric is designed to fit comfortably and securely, providing maximum comfort during wear.



Waterproof to not only protect core protective materials but also make periodic cleaning quick and easy.



Black (Gen 3)



Red (Gen 3)



Sky Blue (Gen 2)



Tiger Lily (Gen 2)



Grey (Gen 2)



Purple (Gen 3)



Denim (Gen 2)



Olive (Gen 2)



Geranium (Gen 2)



Navy (Gen 3)

Nylon - Standard Range

Our nylon fabric is sturdy. Resistant to tares, waterproof and abrasion resistant.



Black Nylon



Burgundy Nylon



Grey Nylon



Forest Green Nylon



Green Nylon



Hot Pink Nylon



Light Royal Nylon



Navy Nylon



Orange Nylon



Purple Nylon



Red Nylon



Royal Nylon



Tan Nylon



Teal Nylon



Yellow Nylon

Ripstop - Reinforced Nylon

Ripstop fabric is a type of material that is characterized by its strong, durable, and tear-resistant weave.



Black Ripstop



Brown Ripstop



Burgundy Ripstop



Green Ripstop



Navy Ripstop



Purple Ripstop



Forest Green Ripstop



Royal Blue Ripstop



Red Ripstop



Silver Ripstop

Designer - Foundation Range

Our designer fabrics have a durable polyester base similar to our nylon range. Foundation fabrics are usually always available with changes rare, with this range pattern coding your fleet of personal radiation protection has never been easier.



70s Flowers



Animal Farm



Butterflies



Camo - Army



Camo - Blue



Camo - Digital



Camo - Light Pink



Camo - Purple



Chicklets - Blue



Chicklets - Multi



Crayon Hearts



Dalmations - Red



Dots - Candy Pink

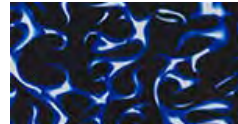

Flames - Blue



Flames - Red



Galaxy - Blue



Galaxy - Multi



Giraffe

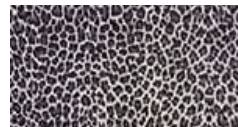

Leopard



Mamba - Pink

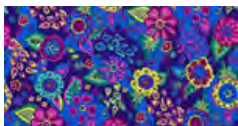

Mardi Gras



Mystery - Multi



Painted Dragon



Paw Prints - Pink



Paw Prints - White



Plaid - Purple



Rainbow

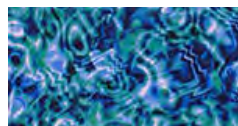

Ripple - Teal



Sheep



Sheep - Pink

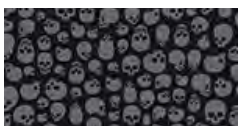

Skulls - Grey

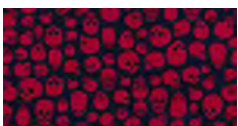

Skulls - Red

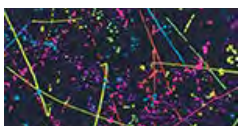

Splash



Stars



Stars and Stripes



Tiger



Zebra



View Latest Fabric Range Online

<https://www.imgsol.com/fabric-selection/>

Designer - Select Range

Select fabrics are more seasonal and limited in nature with changes occurring more frequently than the foundation range, with this range you can find something more unique and expressive.



Animal River



Brenda Comic Beige



Brenda Comic Black



Camo - Woodland



Camo - Navy



Camo - Pink



Chicklets - Purple



Circles



Dots - Pink



Filigree - Purple



Hatchet - Blue



Hawaii Postcard



Hibiscus - Blue



Hibiscus - Wine



Mamba - Blue



Mantis - Blue



Neon Signs

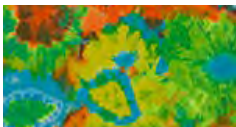

Neon Tie-Dye - Green

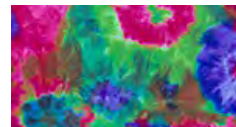

Neon Tie-Dye - Purple



Paw Prints - Black



Plaid - Blue



Plaid - Green



Plaid - Pink



Snake Skin



Space

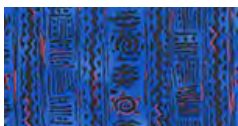

Surf Wax



Sweet Pea

Exclusive Range

Exclusive fabrics have been graphically designed by RADsafe, this range offers the availability of foundation fabrics and the uniqueness of select fabrics as they are only available from RADsafe.



Australian Steel



Australian Carbon

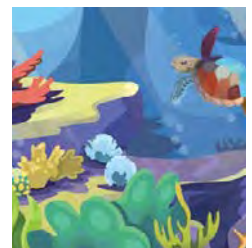
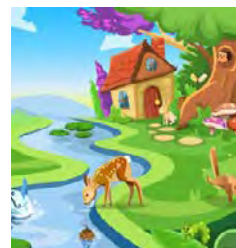

New paediatric fabrics coming soon from Imaging Solution's Virtual Environment Range.

Core Materials

Imaging Solutions has developed and formulated RADsafe's core materials, **RADcore** in response to market demand for safe and reliable protection against ionizing radiation. You can be assured that RADcore materials will provide the protection and compliance specified as a result of highly evolved quality processes which are also supported by random and periodic independent RADlab attenuation testing.

Our own design and manufactured core materials, Optima, Assure and Lite, are high-performing materials that are designed and formulated to meet various leading international standards including IEC, DIN and ASTM.

RADcore materials are all lead-free and leverage the radiation attenuation characteristics of elements such as antimony and bismuth, which are encapsulated in an advanced plasticized polyvinyl chloride formulation.

RADcore material formulations have been optimized to provide high radiation attenuation performance at reduced weights under relevant standards while retaining their strength, flexibility and durability, making them the perfect option for your personal radiation protective needs. RADcore material formulations are also REACH compliant, and being lead-free, these materials can be disposed of without the hazardous challenges of handling lead or other chemicals that pose high risks to human health and the environment.



RADcore



Why Choose RADcore?

- Tailored wide range of applications and standards/regions
- Optimised radiation attenuation performance to weight ratios
- Independent testing and highly evolved quality processes
- Advanced formulation featuring high flexibility and durability
- Specialised lead-free, single, and bi-layers designs and formulations
- REACH compliant materials, minimising health, and environmental impacts

RADcore OPTIMA™

RADsafe Optima core material utilises bilayer design to achieve high radiation attenuation performance and minimal secondary radiation across a range of x-ray energies while also featuring reduced weight compared to traditional lead vinyl and single layer core materials of similar comprehensive radiation attenuation performance.

RADsafe Optima's performance characteristics are achieved by leveraging the high primary radiation attenuation to weight performance of the element antimony in the outer layer while ensuring secondary radiation attenuation with the element bismuth in the inner layer, these layers are thermally fused together into a single bi-layer material ensuring consistency, durability, and inner strength.

RADsafe Optima core material is compliant to the leading international standard IEC 61331-1:2014.

RADsafe's Optima core bilayer design achieves an approximate 20-40% reduced absorbed dose when compared to lead, low-lead and non-lead single layer core materials. Its overall holistic approach to protection provides a measured lead equivalency up to 45% greater than that of traditional antimony dominant direct beam compliant materials when tested to broad beam methodologies.

RADsafe Optima core material has been designed with the clinician in mind, it provides for the perfect balance of protection and ergonomics and is suitable for all personal radiation protection products.

RADsafe Assure core material is a single layer, bismuth dominant material yielding high primary and secondary radiation attenuation performance across a wide range of x-ray energies while feature a modest weight reduction compared to traditional lead vinyl.

RADsafe Assures performance characteristics are “lead-like”, its measured lead equivalence closely resembles that of lead, this is primarily due to bismuth’s atomic element positioning to that of the lead benchmark.

RADsafe Assure core material is compliant to the leading international standard IEC 61331-1:2014.

RADsafe Assure core material provides for as the name implies, Assured protection when compared to the lead benchmark, it is suitable for all personal radiation protection products where weight is not a primary concern, it is ideal for patient protection.

RADsafe Lite core material is a single layer, antimony dominant material yielding high primary radiation attenuation performance at specific x-ray energies, it minimises the antimony required and forgoes high concentrations of other elements that provide improved secondary radiation attenuation for significantly reduced weight when compared to other core materials and especially standard lead vinyl.

Given this RADsafe Lite core material is only compliant to the ASTM F2547-18 direct beam standard and potentially other direct/narrow beam standards which don’t provide for the measurement of secondary radiation.

RADsafe Lite core material is compatible in personal radiation protection where there is a high ergonomic requirement and reduced concern for holistic radiation attenuation performance.

RADcore



Please read the ‘Evaluating Your Core Solutions’ article page 104 of this catalogue to assist with your selection.

OPTIMA™

Material Type	kV Range	Standards	Configurations mmPb LE	Ref. Weight 0.25mmPb LE	Primary Atten. Elements	Range
Bi-Layer Non-Lead	60-110kV	IEC 61331-1:2014	0.25, 0.35, 0.50	2.90 kg/m ²	Antimony or Tin and Bismuth	Premium
AL-Layer Non-Lead <i>(limited availability)</i>	50-110kV	IEC 61331-1:2014	0.25, 0.35, 0.50	2.96 kg/m ²	Antimony or Tin and Bismuth	Advantage
Bi-Layer Low-Lead	60-110kV	IEC 61331-1:2014	0.25, 0.35, 0.50	2.90 kg/m ²	Lead	Essential
Bi-Layer+ Low-Lead	50-150kV	IEC 61331-1:2014	0.25, 0.50, 0.75, 1.00	3.20 kg/m ²	Lead	Advantage

ASSURE™

Material Type	kV Range	Standards	Configurations mmPb LE	Ref. Weight 0.25mmPb LE	Primary Atten. Elements	Range
Non-Lead <i>(limited availability)</i>	50-150kV	IEC 61331-1:2014	0.25, 0.35, 0.37, 0.50, 0.70, 0.75, 1.00 etc..	3.32 kg/m ²	Bismuth	Advantage

LITE™

Material Type	kV Range	Standards	Configurations mmPb LE	Ref. Weight 0.25mmPb LE	Primary Atten. Elements	Range
Non-Lead	80,100kV	ASTM F2547-18	0.25, 0.35, 0.37, 0.50, 0.70, 0.75, 1.00 etc..	2.60 kg/m ²	Antimony, Cerium and Samarium	Advantage

Alternatives

Material Type	kV Range	Standards	Configurations mmPb LE	Ref. Weight 0.25mmPb LE	Primary Atten. Elements	Range
KT-LS Non-Lead <i>(limited availability)</i>	60-110kV	IEC 61331-1:2014	0.25, 0.35, 0.50	2.92 kg/m ²	Lead	Essential
NL-NPL Non-Lead <i>(coming soon)</i>	60-110kV	IEC 61331-1:2014	0.25, 0.35, 0.50	3.00 kg/m ²	Antimony, Cerium and Samarium	Advantage

Apron Accessories



Visor

Straight

Contoured

Thyroid Collars

An essential accessory for protection against scatter radiation. These are available in three different configurations consisting of the Contoured, Straight, and Visor models. Each of these shields are designed to accommodate for different body types and for the desired surface area of protection. This versatility ensures optimal protection and comfort.

Customisable	Trim, Fabric, Embroidery, Apron Attachment <i>(recommended to match apron)</i>
Fastener Type	Hook and Loop, Magnetic
Lead Equivalency	0.50mmPb LE (Standard) 0.35mmPb LE <i>(recommended to match front of apron, must be 0.35mmPb LE or above)</i>
Sizes	X-Small: 30cm - 38cm (11.8" - 15.0") Regular: 36cm - 44cm (14.2" - 17.3") X-Large: 42cm - 50cm (16.5" - 19.7") <i>(neck circumference)</i>

Thyroid Collar - Contoured	RAD-AC-TC-CT
Thyroid Collar - Straight	RAD-AC-TC-ST
Thyroid Collar - Visor	RAD-AC-TC-VS



Suspenders For Skirt

RADsafe® Suspenders for Skirt are designed to assist in maintaining the recommended position of the protective skirt on the wearer to shield against radiation protection.

Suspenders For Skirt	RAD-EC-AP-SS
-----------------------------	--------------



Smart Caps

Created with one only one objective in mind – to protect the user’s brain from radiation exposure. This form of protection was achieved by the three different styles consisting of our Tie model, Hook & Loop closure, and the Elastic. Each variation offers exceptional comfort and durability for long procedures.

Customisable	Trim, Fabric, Embroidery, Apron Attachment <i>(recommended to match apron)</i>
Fastener Type	Tie, Hook and Loop, Elastic
Lead Equivalency	0.50mmPb LE (Standard) 0.35mmPb LE 0.25mmPb LE <i>(recommended to match front of apron)</i>
Sizes	Small: 53cm (21") Medium: 56cm (22") Large: 59cm (23") <i>(maximum head circumference)</i>

Smart Cap	RAD-AC-CP
------------------	-----------



Anti-Slip For Skirt

RADsafe® Anti-Slip for Skirt is a resistant anti-slip material to avoid slipping and accurate sizing for the wearer. The accessory provides ultimate comfort and is placed inside the front and rear of the protective skirt.

Antislip For Skirt	RAD-EC-AP-AS
---------------------------	--------------



Disposable Smart Caps

Created with one only one objective in mind – to protect the user’s brain from radiation exposure. This variation of our Smart Caps is offered in a disposable and single-use unit to aid in infection control efforts. Available in a box of 20.

Fastener Type	Tie
Lead Equivalency	0.25mmPb LE (Standard)
Sizes	One Size Fits All (head circumference 50cm - 59cm)

Cap Disposable - 0.125mmPb LE	RAD-AC-DC-12
Cap Disposable - 0.125mmPb LE Sterile	RAD-AC-DC-12-S
Cap Disposable - 0.250mmPb LE	RAD-AC-DC-25
Cap Disposable - 0.250mmPb LE Sterile	RAD-AC-DC-25-S



Arm Sleeve for Vest/Wrap

Provides 360-degree radiation protection from the shoulder region to the elbow joint of the user. This added coverage will give you the peace of mind during procedures. The Arm Sleeve accessory must be ordered with the purchase of an apron to ensure a correct fit.

Customisable	Trim, Fabric, Embroidery, Apron Attachment (recommended to match apron)
Fastener Type	Hook and Loop, Press Studs, Stitched (Permanent)
Lead Equivalency	0.50mmPb LE (Standard) 0.35mmPb LE 0.25mmPb LE (recommended to match front of apron)
Sizes	Short: Extra underarm protection (No extension) Regular: 15cm (5.9") from underarm

Arm Sleeve for Vest/Wrap RAD-AC-AS



Standard

Flipper

Shin Guards (Pair)

Ensure protection by shielding the lower long bone of the leg from ionizing radiation. The Standard model will cover the knee region to the top of the ankle joint. The Flipper has the same coverage and includes added protection over the tarsal bones. Each model is easily adjustable to ensure a perfect fit.

Customisable	Trim, Fabric, Embroidery, Apron Attachment
Fastener Type	Tie, Hook and Loop, Elastic
Lead Equivalency	0.50mmPb LE (Standard) 0.35mmPb LE 0.25mmPb LE (recommended to match front of apron)
Dimensions (WxL)	Small - 26cm x 34cm (10.2" x 13.4") Medium - 29cm x 37cm (15.4" x 14.6") Large - 32cm x 40cm (12.6" x 15.7")

Shin Guards (Pair) RAD-AC-SG



Arm Guard for Vest/Wrap

Offers radiation protection for the upper arm region of the user. With mobility in mind for this design, the Arm Guard allows a full range of hand movement for the user to aid in performing various tasks comfortably. This accessory must be ordered with the purchase of an apron to ensure a correct fit.

Customisable	Trim, Fabric, Embroidery, Apron Attachment (recommended to match apron)
Fastener Type	Hook and Loop, Press Studs, Stitched (Permanent)
Lead Equivalency	0.50mmPb LE (Standard) 0.35mmPb LE 0.25mmPb LE (recommended to match front of apron)
Sizes	Short: Extra underarm protection (No extension) Regular: 15cm (5.9") from underarm

Arm Guard for Vest/Wrap RAD-AC-AG



Mitten for Angio

The RADsafe® Mitten for Angio offers a range of motion and guards both wearer's hands from X-Ray radiation during major and minor X-Ray inducing procedures including Angio.

Customisable	Trim, Fabric, Embroidery
Lead Equivalency	0.50mmPb LE (Standard) 0.35mmPb LE 0.25mmPb LE
Sizes	One Size Fits All

Mitten for Angio RAD-AC-MA



Mitten with Slit

The RADsafe® Mitten with Slit provides high quality protection for the user's hand during procedures. This Mitten design has a unique slit applied for additional support and mobility.

Customisable	Trim, Fabric, Embroidery
Lead Equivalency	0.50mmPb LE (Standard) 0.35mmPb LE 0.25mmPb LE
Sizes	One Size Fits All

Mitten with Slit RAD-AC-MS



Back Relief Belt (Replacement)

Engineered to offer comfort and lumbar support for the apron user. The belt removes the unwanted weight from the shoulders and redistributes it to the core and lumbar region for a more ergonomic fit. The supportive belt is made from a neoprene bound elastic that features high quality materials. This accessory comes standard with an adjustable buckle which promotes a secure and comfortable fit. This back relief belt is provided as a replacement for back relief styled aprons.

Sizes	X Small: 65 - 90cm Small: 70 - 95cm Medium: 75 - 100cm Large: 80 - 105cm X Large: 85 - 110cm
-------	--

Back Relief Belt (Replacement) RAD-AC-BR



Apron and Accessory Storage and Care



RADfresh Disposable Thyroid Covers

Assists in protecting the Thyroid Shield from deterioration due to sweat, cosmetics, and general wear and tear. The durable, hydrophobic fabric supports improved hygiene and helps prolong the Thyroid Shield's lifespan. Box of 100.

Contoured - Designed for RADsafe®	RAD-FR-TC-CT
Straight - Designed for RADsafe®	RAD-FR-TC-ST
Classic	RAD-FR-TC-CL

RADfresh® Apron Carry Bag

An excellent way to ensure your garments are safely stored and protected during transit. Our Apron Carry Bags are fully customizable with your choice of fabric, colour, or pattern.

Dimensions	75cm (L) x 25cm (W)
RADfresh™ Apron Carry Bag	RAD-FR-CB



Apron Cleaning Solutions

Regular use of appropriate cleaners and wipes can assist with increasing your personal radiation protection product lifespan along with assisting in infection control.

For more information on recommended cleaning and disinfectant products available in your region and further advice, please contact the Imaging Solutions Customer Service Team.





Mobile Apron Trolley

A durable system that is used to store radiation protection garments. The Trolley helps combat premature wear of your Apron by minimizing creases in the core material and outer fabric. This lightweight design features four strong omni-directional locking castors, for easy mobility. This Trolley is available in two high quality finishes, consisting of our brushed stainless-steel and a powder-coat variation.

This is configurable in three different sizes to support either 10 aprons, 15 aprons, or 20 aprons.

Apron hangers are not included (pictured as an example), but are available for purchase in Stainless Wire, and Powder Coated options

Sizes	10 Aprons: 60 x 75 x 151 cm
	15 Aprons: 85 x 75 x 151 cm
	20 Aprons: 115 x 75 x 151 cm

Powder Coated - 10 Aprons	RAD-ST-MTR10-PC
Brushed Stainless - 10 Aprons	RAD-ST-MTR10-SS
Powder Coated - 15 Aprons	RAD-ST-MTR15-PC
Brushed Stainless - 15 Aprons	RAD-ST-MTR15-SS
Powder Coated - 20 Aprons	RAD-ST-MTR20-PC
Brushed Stainless - 20 Aprons	RAD-ST-MTR20-SS



Premium Apron Hangers

An essential accessory for your garment storage system. The robust Hangers can hold up to 50lbs (22.7kg) without stressing the outer material or frame. This item is available in two different configurations consisting of a stainless steel and powder coat variation.

Apron Hanger - Stainless (Box of 5)	RAD-ST-APH-SL5
Apron Hanger - Powder Coated (Box of 5)	RAD-ST-APH-PC5



Valet Apron Trolley

An excellent choice for time sensitive storage of radiation protection aprons. This model is configurable to support your choice of 6 or 10 'built-in' hangers, for an efficient retrieval and storage process.

This durable design is available in a brushed stainless-steel frame and a powder-coated variation.

Sizes	6 Aprons: 65 x 64 x 140 cm
	10 Aprons: 110 x 64 x 140 cm

Powder Coated - 6 Aprons	RAD-ST-VTR6-PC
Brushed Stainless - 6 Aprons	RAD-ST-VTR6-SS
Powder Coated - 10 Aprons	RAD-ST-VTR10-PC
Brushed Stainless - 10 Aprons	RAD-ST-VTR10-SS

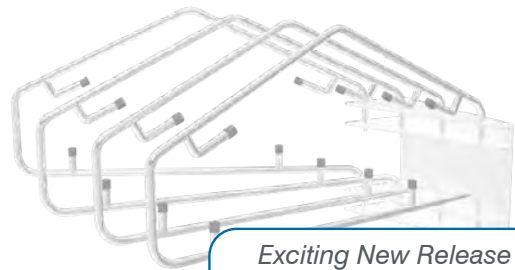

*Exciting New Release
Coming Soon*

Premium Wall Rack

A minimalist style storage system, that removes the clutter of a free-standing unit. The Wall Rack features nibs, which allows a streamlined compatibility for hanging garments of any model. This model is configurable to support your choice of 3 to 5 garments at a time.

Overall weight - 5kg

Base plate dimensions - 155mm x 155mm

Left Sided Swing Arm Mounted Storage	RAD-ST-PWR5-L
Right Sided Swing Arm Mounted Storage	RAD-ST-PWR5-R



Mobile Multiple Apron Hanger with 10 Swing Arms

The Mobile Multiple Apron Hanger with 10 Swing Arms is a versatile and sturdy storage solution for your lead aprons. With its generous, stable base and welded construction, this apron rack is virtually untippable and can hold up to 10 aprons safely, even the heaviest lead.

Designed to help you keep your department uncluttered and organized, the hanger has pivoting arms that fold flat against the wall, and it moves on low profile pallet casters, allowing you to easily move it around X-ray departments, Cath.Labs, O.R., and other areas. The pedestal design is counter weighted for stability, making it a reliable option for apron storage.

This apron rack is a space-saving and convenient option for your apron storage needs.

Dimensions (LxWxH) 51cm x 61cm x 127cm (20" x 24" x 50")

Mobile Multiple Apron Hanger

PSP-RAR-M10S-HB



Garment Style Mobile 10 Arm Apron Rack

The Garment Style Mobile 10 Arm Apron Rack is the ultimate solution for efficiently storing and organizing your radiology department's aprons. Its 10 pivoted arms fan out to 180 degrees, providing ample space for multiple aprons. The rack is mounted on locking casters, allowing for easy mobility and convenience. Its high-tech finish of chromium and white adds a modern touch to any room decor.

With a high weight capacity this rack can handle even the heaviest of aprons. It's small footprint design is the perfect addition to any radiology department. The rack is built to last and provide reliable storage for your aprons.

Dimensions (LxWxH) 132cm x 61cm x 137cm (52" x 24" x 54")

Capacity 270kg (600lbs)

Garment Style Mobile

PSP-RAR-MSA10



8-Peg Mobile Leaded Apron Rack

Our mobile leaded apron rack has a 5-leg, caster-equipped base, making it the perfect portable apron rack to store and transport up to 8 aprons. This solid aluminum rack is sturdy and stable, and can be quickly moved out of the way when space is at a premium.

Mobile Leaded Apron Rack

PSP-RAR-SAR8

Mobile Leaded Apron Rack with Glove Rack

PSP-RAR-SAR8-G

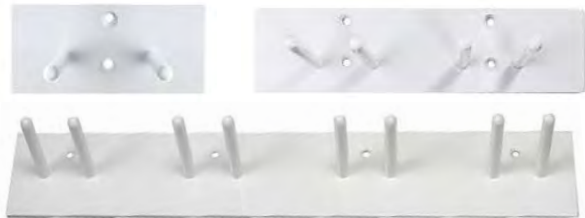

Peg Apron Racks

The Wall Mounted Lead Apron Peg Rack is a strong lead apron rack made from durable steel and has an electro-magnetic powder coating.

Plus, when securely mounted to a wall, our lead apron peg rack can hold from 1 to 9 lead aprons.

Pegs	Item Dimensions	Item Weight	Item Code
2	6" x 3" x 4.5"	2.2	PSP-RAR-P1
4	12" x 3" x 4.5"	4.2	PSP-RAR-P2
8	19" x 3" x 4.5"	7.2	PSP-RAR-P4
14	36" x 3" x 4.5"	13.6	PSP-RAR-P7
18	50" x 3" x 4.5"	18	PSP-RAR-P9



Wall Mounted Multi Apron and Glove Rack

- Ideal wall mount rack for storing multiple pairs of gloves and aprons
- Also has convenient bar to hold thyroid collars
- Sturdy steel construction
- Neutral off-white color
- Latex Free
- Approximate Dimensions: 19" W x 20" H

Multi Apron and Glove Rack WM PSP-RAR-821



LEFT SWING

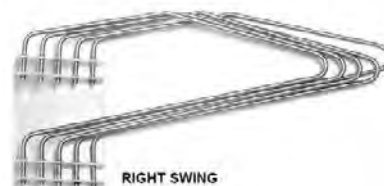

RIGHT SWING

Five-Arm Lead Apron Wall Rack

The Wall Rack offers great storage capacity. The heavy duty metal rack holds up to 5 aprons on 5 arms to a maximum suggested weight of 110 lbs. It features five chromium plated pivoting hangers which can flatten out nearly 180 degrees. It's great for storage behind doors, equipment, etc... rush aprons out of the way!!

Mounting Hardware Not Included Dimensions are as follows:

- Arms extend perpendicular from the wall on which the unit is mounted 22.5" at the maximum point
- When stored flat the arms are 25.5" left to right
- Total Height when flat from bottom of plate to highest point of swing arm (Hanger) is 10"
- Arm height is 6.5"
- Overall Plate size 6" W x 6" H
- When flat the highest point from the wall (Mounting bracket) is 3"

Left Swing Arm Mounted Storage PSP-RAR-SA5L

Right Swing Arm Mounted Storage PSP-RAR-SA5R



Wall Mounted Lead Apron Storage Rack with 5 Full Swing Arms

- Wall mounted 5 apron storage unit has 5 pivoting apron hangers
- Each hanger can swing a full 180 degrees to either side
- Rack holds up to 110 lbs.
- Specifications: 4 5/8" H x 17" W*

Swing Arm Mounted Storage PSP-RAR-F5S



Child Frontal Apron with Comfortwear

Front-only radiation protection garment. This Apron features an adjustable buckle fastener for a secure and ergonomic fit. Additionally, the shoulder padding offers exceptional comfort for our younger patients.

Customisable	Trim, Fabric, Embroidery
Fastener Type	Hook and Loop (Standard), Buckle
Lead Equivalency	0.50mmPb LE (Standard) 0.35mmPb LE (On Request) 0.25mmPb LE (On Request)
Sizes	Child 3-6 Years: 100cm (39.4") Child 6-9 Years: 116cm (45.9") Child 9-12 Years: 133cm (52.5") <i>(maximum chest/bust circumference)</i>

Child Frontal Apron Child 3-6 Years	RAD-PP-AP-FB-SC
Child Frontal Apron Child 6-9 Years	RAD-PP-AP-FB-MC
Child Frontal Apron Child 9-12 Years	RAD-PP-AP-FB-LC

Child Wrap Around

The RADSafe Wrap Around is a front and back radiation protection garment. This Apron features an adjustable buckle fastener for a secure and ergonomic fit. Additionally, the shoulder padding offers exceptional comfort for our younger patients. The 360-degree coverage of this apron is an excellent choice to maximize protection.

Customisable	Trim, Fabric, Embroidery
Fastener Type	Hook and Loop (Standard)
Lead Equivalency	0.50mmPb LE (Standard) 0.35mmPb LE 0.25mmPb LE
Sizes	Child 3-6 Years: 100cm (39.4") Child 6-9 Years: 116cm (45.9") Child 9-12 Years: 133cm (52.5") <i>(maximum chest/bust circumference)</i>

Child Wrap Around Child 3-6 Years	RAD-PP-AP-WA-SC
Child Wrap Around Child 6-9 Years	RAD-PP-AP-WA-MC
Child Wrap Around Child 9-12 Years	RAD-PP-AP-WA-LC



Patient Breast/Scoliosis Shole

Designed to protect the sensitive breast tissue from scatter radiation. This accessory is predominantly utilized for spinal scans and the Shole ensures the patient's breast region is properly covered, while not hindering the spinal view during examination.

Customisable	Trim, Fabric, Embroidery
Fastener Type	Hook and Loop, Strap with Buckle
Lead Equivalency	0.50mmPb LE (Standard) 0.35mmPb LE (On Request) 0.25mmPb LE (On Request)
Sizes (WxH)	Medium: 15cm x 40cm (5.9" x 15.7") Large: 18cm x 50cm (7.1" x 19.7")

Patient Breast Shole - Medium/Adolescent	RAD-PP-BS-MA
Patient Breast Shole - Large/Adult	RAD-PP-BS-LA
Patient Breast Shole - Set - 2 Sizes	RAD-PP-BS-SET



Patient Half Apron

Front-only protection against scatter radiation. This full-sized garment includes an adjustable buckle fastener to ensure a comfortable fit.

Customisable	Trim, Fabric, Embroidery
Fastener Type	Hook and Loop (Standard), Buckle
Lead Equivalency	0.50mmPb LE (Standard) 0.35mmPb LE (On request) 0.25mmPb LE (On request)
Sizes (WxH)	Small: 40cm x 50cm (15.7" x 19.7") Medium: 50cm x 55cm (19.7" x 21.7") Large: 60cm x 60cm (23.6" x 23.6")

Patient Half Apron Large/Adult	RAD-PP-AP-HA-LA
Patient Half Apron Medium/Adult	RAD-PP-AP-HA-MA
Patient Half Apron Small/Child	RAD-PP-AP-HA-SC
Patient Half Apron Set 3 Sizes	RAD-PP-AP-HA-SET



Patient Scrotum/Ovary Shield Set

Comes standard with four interchangeable shields. Each shield represents a different size to provide a universal fit for the patient. This Shield Set features an adjustable hook-and-loop closure.

Customisable	Trim, Fabric, Embroidery
Fastener Type	Hook and Loop, Belt with Buckle
Lead Equivalency	1.00mmPb LE (Standard) <i>(must be 1.00mmPb LE)</i>
Sizes (WxH)	X-Small: 11cm x 10cm (4.3" x 3.9") Small: 14cm x 12cm (5.5" x 4.7") Medium: 17cm x 14cm (6.7" x 5.5") Large: 22cm x 17cm (8.7" x 6.7")

Patient Scrotum/Ovary Shield Set - 4 Sizes	RAD-PP-SO-SET
---	---------------



Patient Gonad Apron

Provides front-only protection against scatter radiation. This compact design features an adjustable hook-and-loop for a versatile fit.

Customisable	Trim, Fabric, Embroidery
Fastener Type	Hook and Loop (Standard), Buckle
Lead Equivalency	0.50mmPb LE <i>(must be 0.50mmPb LE or above)</i>
Sizes (WxH)	X-Small: 25cm x 20cm (9.8" x 7.9") Small: 30cm x 30cm (11.8" x 11.8") Medium: 40cm x 37cm (15.7" x 14.6") Large: 50cm x 45cm (19.7" x 17.7")

Patient Gonad Apron - Infant/Child	RAD-PP-AP-GA-XC
Patient Gonad Apron - Small/Child	RAD-PP-AP-GA-SC
Patient Gonad Apron - Medium/Adult	RAD-PP-AP-GA-MA
Patient Gonad Apron - Large/Adult	RAD-PP-AP-GA-LA
Patient Gonad Apron Set 4 Sizes	RAD-PP-AP-GA-SET



Patient General Shield (Reusable Drape)

A Reusable Drape that is designed to protect healthcare personnel from ionizing radiation. This lightweight drape is highly versatile for an array of functions.

Customisable	Trim, Fabric, Embroidery
Fastener Type	None
Lead Equivalency	1.00mmPb LE (On Request) 0.50mmPb LE (Standard) 0.35mmPb LE (On Request) 0.25mmPb LE (On Request)

Sizes	Small: 60cm x 30cm (23.6" x 11.8") Medium: 90cm x 60cm (35.4" x 23.6") Large: 120cm x 90cm (47.2" x 35.4")
-------	--

Patient General Shield - Small	RAD-PP-GS-S
Patient General Shield - Medium	RAD-PP-GS-M
Patient General Shield - Large	RAD-PP-GS-L



Patient Breast Shield

Designed to protect the sensitive breast tissue of a patient during scans of nearby anatomy. This durable design offers optimal protection.

Customisable	Trim, Fabric, Embroidery
Fastener Type	Hook and Loop, Strap with Buckle
Lead Equivalency	0.50mmPb LE (Standard) 0.35mmPb LE (On Request) 0.25mmPb LE (On Request)

Sizes (WxL)	Medium: 60cm x 18cm (23.6" x 7.1") Large: 50cm x 15cm (19.7" x 5.9")
-------------	---

Patient Breast Shield - Medium/Adolescent	RAD-PP-BT-MA
Patient Breast Shield - Large/Adult	RAD-PP-BT-LA
Patient Breast Shield - Set - 2 Sizes	RAD-PP-BT-SET



Patient Panoramic Dental Apron

A front only radiation protection garment that includes a removable thyroid collar. This garment was specifically designed for dental panoramic radiography.

Customisable	Trim, Fabric, Embroidery
Fastener Type	Hook and Loop (Standard), Buckle
Lead Equivalency	0.50mmPb LE (Standard) 0.35mmPb LE (On request) <i>(Must be 0.35mmPb LE or above)</i>

Sizes (WxH)	Small: 45cm x 60cm (17.7" x 23.6") Large: 60cm x 80cm (23.6" x 31.5")
-------------	--

Panoramic Dental Apron - Child	RAD-PP-AP-PA-SC
Panoramic Dental Apron - Large/Adult	RAD-PP-AP-PA-LA
Panoramic Dental Apron Set - 2 Sizes	RAD-PP-AP-PA-SET



Patient Dental Apron

A front only radiation protection garment that includes a removable thyroid collar. This garment was specifically made for patient use in dentistry settings due to its versatile design.

Customisable	Trim, Fabric, Embroidery
Fastener Type	Hook and Loop (Standard), Buckle
Lead Equivalency	0.50mmPb LE (Standard) 0.35mmPb LE (On request) <i>(Must be 0.35mmPb LE or above)</i>

Sizes (WxH)	Small: 45cm x 60cm (17.7" x 23.6") Large: 60cm x 80cm (23.6" x 31.5")
-------------	--

Patient Dental Apron - Small/Child	RAD-PP-AP-DA-SC
Patient Dental Apron - Large/Adult	RAD-PP-AP-DA-LA
Patient Dental Apron - Set - 2 Sizes	RAD-PP-AP-DA-SET

Asset Tracking and Management



RADtrack® is a personal radiation protection apparel tracking, reporting and management system suitable for use by organisations of all sizes. The system is simple-to-use and easy-to-access. RADtrack® can save you, your department or your facility significant effort, time and money, and helps you manage the risk associated with the regular screening of personal radiation protection apparel.

Why do you need RADtrack®?

As healthcare industries have evolved and become more complicated, keeping track of personal radiation protective aprons and other apparel has become more and more difficult. Hospital departments have diversified and enlarged, with items often moving from one department, or even one facility, to another.

RADtrack® provides you with a simple, stress-free way to label, track and report on your radiation protection apparel. It helps you manage the risk associated with apparel inspections - a process required and monitored by regulating bodies in most countries.

Easy-to-Use Functionality for Simple Tracking and Reporting on Fleets of Any Size.

Easy To Use Dashboard

The RADtrack™ Dashboard is your starting point when you log into the RADtrack™ system. The Dashboard page displays quick and convenient reference information such as order details or apparel items requiring inspection.

- Create system reports such as apparel or inspection reports
- Custom design and create your own reports and save it for easy recall
- Define or redefine users or notification settings
- Manage users and user settings
- An alert system providing a list of all apparel that require inspection

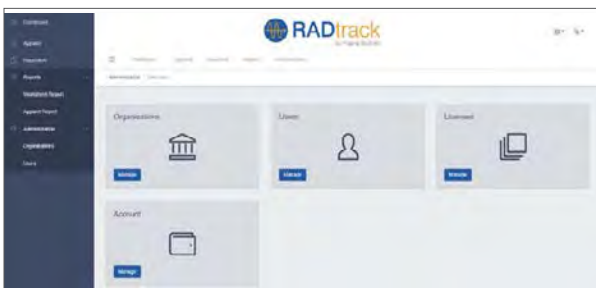

Exporting Support

Export the worksheet report for use later with your inspections using a barcode scanner and RADtrack.

Features and Benefits

The RADtrack® system has the following features and benefits:

- Safe and secure with easy online access.
- Accessible on PC and Mobile.
- Manage risk and protect your investment.
- Effective and affordable apparel tracking through full life-cycle.
- Ideal for department, site or enterprise level.
- Ideal for use with RADsafe™ aprons, thyroid collars, and patient protection accessories.
- Immediate integration into existing workflow.
- User-defined access by individuals, departments or sites via secure username and passwords.
- Unique identification codes (RadIDs/Asset tags) for each apparel item.
- Colour inspection indicators provided allowing users to quickly and easily identify items that have been tested and are compliant.
- High levels of functionality in reporting (templates or design your own report) and managing apparel.
- Custom-defined and automated testing reminders.
- Time-saving barcode scanner and labelling options.

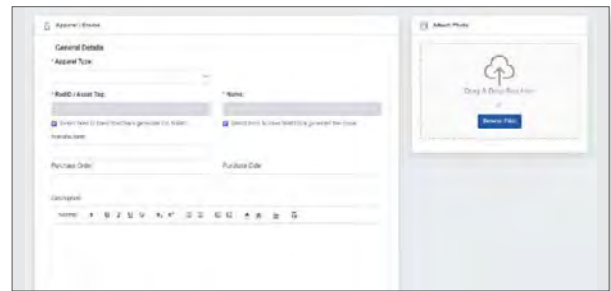

Apparel Management

The Manage Apparel page of the RADtrack™ system allows you to conveniently view a range of individual details about your any of your apparel items held on the system. Essentially, it is a snapshot of everything you will need to know about an apparel item.

- Receive alerts for items that are: not inspected, needs inspection or sent for repair alerts.
- Get basic information on your apparel including the RadID code, type of item, its status, site and department and any relevant order details.
- View apparel specifics such as item style, colours / patterns for outer and inner fabrics, binding colour, gender, size, lead equivalency and protective material type.
- View life-cycle information including item in-service date, last inspection date, inspection due date and scheduled disposal date (if applicable).
- View compliance and testing information such as logged results of previous inspections including acceptance test and all annual inspections.
- Update apparel, upload photo, view apparel history, schedule disposal and print page.

Multiple Language Capabilities

RADtrack was developed as a responsive web application with embedded multi-language capabilities. Select from multiple languages and have RADtrack change in real-time.

Apparel Tracking

Minimal fields required to upload apparel if it has not already been made available in your RADtrack platform. Attach photos at the time of entering your apparel information. Multiple apparel item types available depending on what you want to track. Easily upload images and view apparel inspection details and history through a single page.

Manage acceptance test results at the time of entering individual apparel items whilst you have all of the information available on the screen.

Apparel Inspection

Easily enter inspection results through an interactive and responsive online worksheet. Inline editing capabilities and multiple status options available. RADtrack support barcode scanning for rapid data entry. Choose from multiple status options to track each apparel item when producing an inspection report. Edit the inspection in-line without refreshing the web page.

Simple Configuration

RADtrack™ is just as flexible as it is convenient and useful!

The system can be used for apparel fleets of any size, from small clinics up to large enterprises with multiple sites and hundreds or even thousands of items. It is also flexible enough to be used in any location around the world and with formats you are accustomed to.

On the configuration page, you can set basic settings such as time zones, date formats, initials (of item owners or persons carrying out inspections) as well as site, department or individual contact details.

Multi-user

The RADtrack™ system allows you to define users for all levels along with access levels and permissions. All this may be protected by the use of secure sign-on user names and passwords. The user page also allows you to keep user contact information up-to-date so that users may be contacted when, or if, required.

Fleet Reporting

The RADtrack™ system not only provides a variety of useful in-built reports, it also allows you to create and produce your own. There is no easier way to confidently track and report on your personal radiation protection apparel inspections: RADtrack™ has the inspection reports ready to print!

Instantly generate other types of reports yourself using any of the data in the system. These neat, tidy and easy-to-read reports are indispensable when it is time for an inspection or when you need information on hand in a professional format. They also can be configured to be e-mailed to you weekly, monthly or quarterly (or as required) and it is easy to add company logos to create a truly professional document.

Standard, built-in reports include:

- Individual, departmental or site-based reports
- Inspection reports (results or due-based)
- Apparel basic and specific information reports
- Latest activity reports

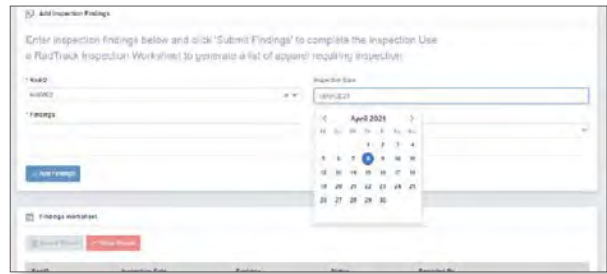

Colour Inspection Indicators

RADtrack® colour inspection indicators provide immediate visual recognition of whether an apparel item has been tested for the current period and is therefore safe to use. The indicators are easily attached to a holder on a RADsafe® apron or to a retrofit tag. Use different colours for different periods to indicate items that have passed testing, need to be tested, are out-of-date, are damaged or any other designation.



Approximate Size:
63 x 16mm

Colour inspection indicators are not necessarily required to be used in order to use the RADtrack® system.

Year 20X1 - Purple (100 Pack)	RAD-RT-CII-Y1
Year 20X2 - Aqua (100 Pack)	RAD-RT-CII-Y2
Year 20X3 - Forrest Green (100 Pack)	RAD-RT-CII-Y3
Year 20X4 - Brown (100 Pack)	RAD-RT-CII-Y4
Year 20X5 - Blue (100 Pack)	RAD-RT-CII-Y5
Year 20X6 - Orange (100 Pack)	RAD-RT-CII-Y6
Year 20X7 - Hot Pink (100 Pack)	RAD-RT-CII-Y7
Year 20X8 - Yellow (100 Pack)	RAD-RT-CII-Y8
Year 20X9 - Green-Lime (100 Pack)	RAD-RT-CII-Y9
Year 20X0 - Red (100 Pack)	RAD-RT-CII-Y0



Custom Serial Numbers Available!

Barcoded Retrofit RADid Tags

Barcoded RADid Tags are aluminium tags which can be retrofitted to existing aprons to uniquely identify them with a RADid. The tags are approximately 62 x 10mm in size, feature a unique identifier and optionally a convenient barcode for workflow and scanning efficiency. Available in a pack of 100 with the appropriate rivets. The RADtrack Application device should be used to attach RADid Tags to your apparel.

Retrofit Tag Application Device	RAD-RF-AD
Retrofit Tag w/o Barcode (100 Pack)	RAD-RF-TG-TXT
Retrofit Tag w/ Barcode (100 Pack)	RAD-RF-TG-BAR

Radiation Attenuating Gloves



When it comes to radiation exposure, the surgeon's hands remain the body part having the greatest exposure.

Latex Free and Lead Free Radiation Attenuating Gloves offers an effective, safer and more sustainable option for healthcare professionals.

IneoGuard™ radiation attenuating surgical gloves are developed by IneoTech using a proprietary formulation of polyisoprene and tungsten as the attenuating material. Our gloves are latex free, lead free, MBT free and DPG free, promoting safer skin protection for healthcare professionals.

Synthetic Polyisoprene, Powder Free Radiation Attenuating Surgical Gloves

Gloves are designed with a unique material composition that offers an enhanced flexibility, enabling excellent tactile sensitivity and prolonged wear without hand fatigue.

Key Features and Benefits

- Latex free¹, Lead free².
- Soft formulation made of synthetic polyisoprene
- Hi-density tungsten composition.
- Enhanced flexibility and comfort for instrument handling.
- Textured finger micro-surface to provide an optimum control.

High Density Attenuation Composition

Designed with a proprietary tungsten composition which is 75% more dense than lead, ineoGuard offers superior attenuation ability than leaded gloves at equivalent thickness.

Lead Free², No DPG³ and No BMT⁴

ineoGuard glove is formulated without DPG and MBT chemical accelerators, promoting skin health and offering a safer option to professionals while reducing lead pollution to the environment.



Product Description

Intended Use	Radiation attenuating surgical gloves to reduce the exposure from harmful scattered ionizing rays on the operator's hand during fluoroscopic procedures. These gloves are not to be used in or next to the primary X-Ray beam.
Material	Soft synthetic polyisoprene containing lead-free radiation attenuating tungsten alloy. Formulated without Diphenylguanidine (DPG) and without Mercaptobenzothiazole (MBT), recently classified as cancer-causing agent in the California Prop-65.
Donning	Powder free, Polymer coated
Colour	Dark grey
Sterilization	Radiation, > = 25kGy
Shelf Life	3 years from the manufacturing date. Store in cool, dry and ozone free place. Keep out of direct sunlight.
Packaging	5 pairs per box
Quality Control	100% of gloves are visually inspected

Physical and Barrier Properties

- Free from hole according to EN455-1: AQL 0.65
 - Resistance to permeation by chemicals according to EN374-1 and EN16523: Type B (K, M, P, T)
 - Glove sizes compliant with EN 455-2. Minimum length: 285mm
 - Physical properties compliant with EN 455-2.
 - Absence of residual powder (powder free) according to EN455-3.
1. Not made with natural rubber latex.
 2. Not formulated with lead.
 3. Not formulated with Mercaptobenzothiazole (MBT) accelerator, California Prop 65 listed carcinogen.
 4. Not formulated with DiphenylGuanidine (DPG) accelerator.

Configurations

	Thickness in mm		
	Cuff	Palm	Finger
Model 1	Min. 0.23	Min. 0.24	Min. 0.27
Model 2	Min. 0.31	Min. 0.32	Min. 0.37

	Thickness in mm			
	60 kVp	80 kVp	100 kVp	120 kVp
Model 1	52%	44%	40%	36%
Model 2	61%	54%	49%	45%

Model 1

Recommended For:

- Cardiac catheterization
- Barium X-rays procedures
- Interventional cardiovascular procedures
- e.g. angioplasty, endovascular stenting
- Intraoperative fluoroscopic procedures
- with the use of C-arm/ mini C-arm

Model 2

Recommended For:

- Orthopedic & trauma fluoroscopic-guided procedures e.g. arthroscopy, dynamic hip screw
- Interventional spine procedures
- Intraoperative fluoroscopic procedures
- with the use of C-arm/ mini C-arm

Ordering

Size	Product Codes	
	Model 1	Model 2
5.5	INT-IG155	INT-IG255
6	INT-IG160	INT-IG260
6.5	INT-IG165	INT-IG265
7	INT-IG170	INT-IG270
7.5	INT-IG175	INT-IG275
8	INT-IG180	INT-IG280
8.5	INT-IG185	INT-IG285
9	INT-IG190	INT-IG290



Why Choose IneoGuard?

Radiation-attenuating gloves are designed to provide protection from scattered ionizing radiations during fluoroscopy procedures.

This property is achieved by loading a significant amount of radio-opaque solid particles into the rubber matrix.

However, introducing such large amounts of particles in a rubber produces an increase of rigidity and a decrease of the glove mechanical resistance. Therefore, the design and manufacture of radiationattenuating gloves present a substantial technical challenge.

Not all brands of radiation-attenuating gloves are made and perform equally.

“ Radiation-attenuating gloves are sophisticated materials. They should meet stringent properties, most of them being antagonist. ”

Radiation-attenuating gloves from various brands were supplied directly from the market place and analyzed according to the following criteria:



Dexterity

- The glove rigidity was assessed by measuring the force (in Newton) needed to elongate the glove by 100% (at finger area)
- The glove thickness (in μm) was measured in various locations. The thickness gradient (in %) is expressed by the ratio of the thicknesses measured in the Index Finger and in the Cuff.



Safe & Responsibly Made

- Most of current radiation-attenuating gloves contain natural rubber, and/or lead, and/or harmful accelerators
- IneoGuard is formulated with an innovative latex-free, lead-free composition that does not contain Diphenyl Guanidine (DPG-free) nor Mercaptobenzothiazole (MBT-free) accelerators.



Performance

- The radiation-attenuating performance was assessed by measuring the filling percentage (%w/w) of the particles in the glove, by thermogravimetric analysis.
- The physical performance was evaluated by measuring the tensile strength of the glove (in MegaPascal).

In-house & External Lab Results:

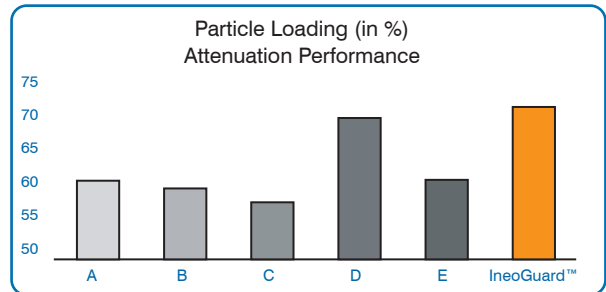
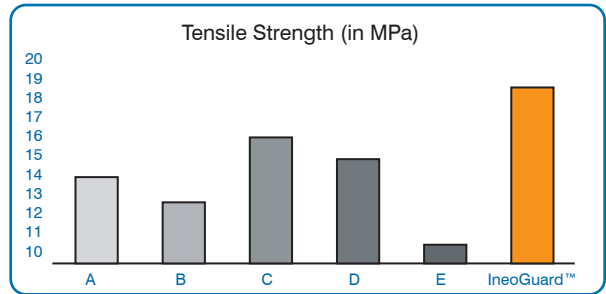
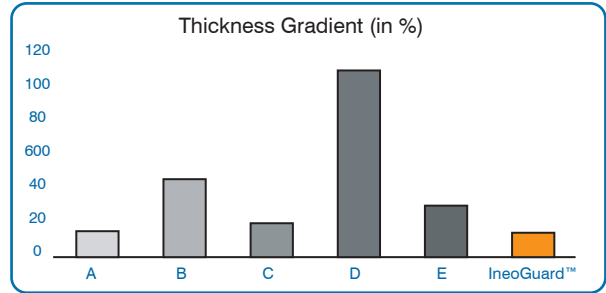
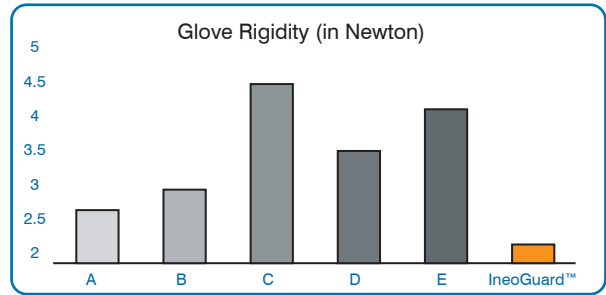

A = Latex, Lead (India) D = Latex-free, Lead-free (USA)
 B = Latex, Lead-free (India) E = Latex-free, Lead-free (Malaysia)
 C = Latex, Lead-free (India)

No Safe Dose Exists

In a recent article published in Japan¹, the hands of 104 orthopaedic surgeons were examined by dermatologists.

31.4% diagnosed with radiation-induced skin injury

5.5% undergone specific dermatological treatment

2.7% had resection of pre-cancerous skin lesions and skin cancer, including radiation keratosis and squamous cells carcinoma.

Pictured Right: Grade 2 : Case with a hyperkeratotic papule (4th finger), rough surface due to hyperkeratosis (1st, 2nd, 3rd fingers), severe deformities, and nail discoloration.

1. Journal of Orthopaedic Science 2022

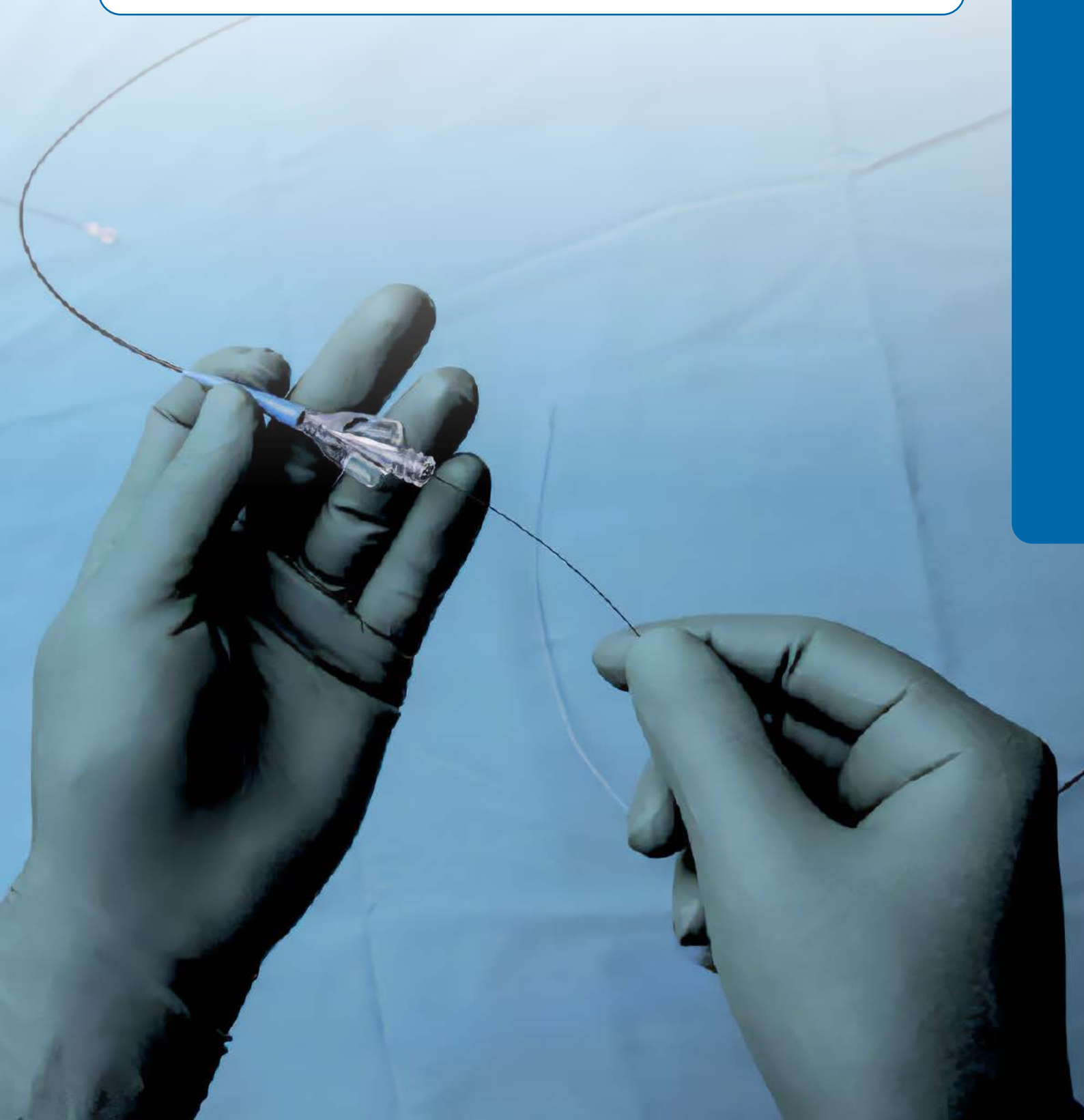

Anti-Scatter Radiation Drapes

Imaging Solutions decision to expand into the anti-scatter drape market was driven through its existing market leadership in the manufacture of personal radiation protection apparel. Imaging Solutions is a fully vertically integrated manufacturer of Radiation Protection apparel and associated products.



Uniquely Imaging Solutions is one of a hand full of suppliers globally who manufacture core radiation attenuation material. This means Imaging Solutions can directly control the quality and performance of the product. The drapes are available with an attenuation level of 0.25mm Pb LE or 0.125mm Pb LE.

- Sterile
- Lead Free
- Light Weight
- Disposable
- Double Adhesive
- Latex Free

In addition to being able to ensure high quality and performance, Imaging Solutions has developed an eco-core material which is fully recyclable, meeting all international standards. The research and development which designed the new eco options reflects the company's ethos to manufacture products which are not only safe, secure and reliable for deployment in medical applications but also protects the environment.

What is Scatter Radiation?

Scatter radiation is defined as a type of secondary radiation that occurs when the beam intercepts an object, causing the beam of X-rays to be scattered in different directions. Scatter radiation usually occurs during diagnostic imaging procedures and can be generated from the following: CT imaging, fluoroscopy, X-ray, mammography, bone mineral densitometry and body composition analysis. During most imaging procedures, the patient's body is the object that deflects the radiation and causes it to scatter around the room, potentially risking clinical healthcare workers and the patient to unnecessary radiation exposure.

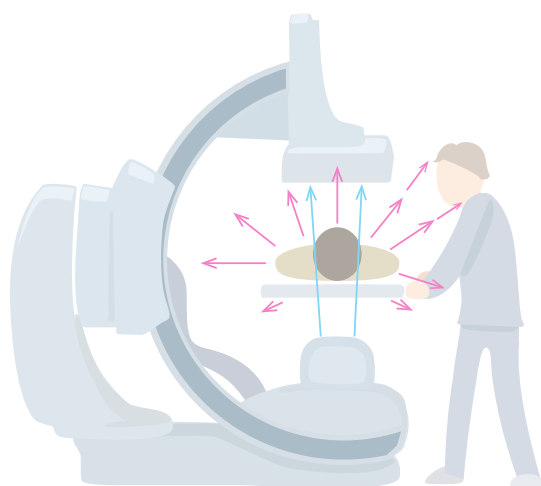

Direct Beam and Scatter Radiation

Direct beam radiation also known as direct radiation occurs when an object comes into contact with a high energy radiation source. During a diagnostic imaging procedure, as the x-ray beam is passed through the patient's body, a doctor or nurse may come in contact with the direct beam if they enter the direct path of the radiation beam. Appropriate radiation protection apparel is just one factor in keeping people safe from the dangers of direct beam radiation.

Scatter radiation is a type of secondary radiation which is characterized as low energy radiation. The scattering of the radiation beams occurs when a direct radiation beam interacts with body tissue, causing the ionising radiation to be scattered indirectly throughout the surrounding clinical operating environment.

In some cases, as with dental offices, the technologist is able to step out of the room during the examination, thus lessening the chance of an accidental exposure from scatter radiation. However, in operating theatres, for example, physicians, nurses and technologists who are near the patient must be protected using the appropriate ant-scatter radiation drapes.

Who is at Risk?

Radiation safety is a common concern for patients, physicians, and clinical healthcare workers in many departments, including interventional cardiology, radiology, and surgery. As the number of interventional procedures increases due to advancements in both technology and clinical efficacy, medical staff are subjected to potential exposure from these sources of radiation. This radiation exposure is dependent on the duration of time, distance from the radiation source, and the physical shielding being implemented.

Radiation exposure over a prolonged time period can produce biological effects that can potentially cause short and long-term health issues. It is important to note that these health effects can be reduced by implementing the appropriate protective measures.

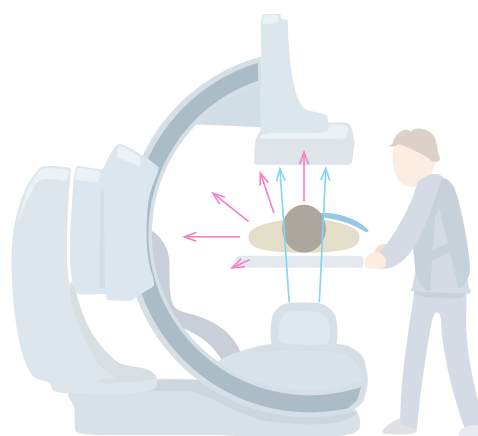



Multipurpose

Multipurpose anti-scatter drapes are designed to reduce scatter radiation at the source, creating a scatter-free zone by reducing harmful ionizing radiation exposure during radial and other types of procedures. Drapes are 43x30cm in size and are provided as a box of 10.

Non Lead Bilayer 0.25mmPb	RAD-DP-MPD-4330-NLB61-20
Non Lead 0.25mmPb	RAD-DP-MPD-4330-NLH55-20
Non Lead 0.125mmPb	RAD-DP-MPD-4330-NLH55-10



Multipurpose with Fenestration

Multipurpose drapes with a rectangular fenestration are designed for needle biopsy or puncture procedures. The drapes are developed to reduce scatter radiation at the source, creating a scatter-free zone, thereby reducing harmful ionizing radiation exposure. Drapes are 43x30cm in size and are provided as a box of 10.

Non Lead Bilayer 0.25mmPb	RAD-DP-MRF-4330-NLB61-20
Non Lead 0.25mmPb	RAD-DP-MRF-4330-NLH55-20
Non Lead 0.125mmPb	RAD-DP-MRF-4330-NLH55-10



Multipurpose with Side Scoop Fenestration

Designed for Subclavian access: Bi-Ventricular Pacemaker Implants, ICS procedures and Bi-Ventricular Pacing. The drapes are developed to reduce scatter radiation at the source, creating a scatter-free zone, thereby reducing harmful ionizing radiation exposure. Drapes are 43x30cm in size and are provided as a box of 10.

Non Lead Bilayer 0.25mmPb	RAD-DP-MSF-4330-NLB61-20
Non Lead 0.25mmPb	RAD-DP-MSF-4330-NLH55-20
Non Lead 0.125mmPb	RAD-DP-MSF-4330-NLH55-10



Multipurpose with Centre Scoop Fenestration

Multipurpose drapes with a centre scoop fenestration are designed for ICS procedures and Bi-Ventricular Pacing. The drapes are developed to reduce scatter radiation at the source, creating a scatter-free zone, thereby reducing harmful ionizing radiation exposure. Drapes are 43x30cm in size and are provided as a box of 10.

Non Lead Bilayer 0.25mmPb	RAD-DP-MCF-4330-NLB61-20
Non Lead 0.25mmPb	RAD-DP-MCF-4330-NLH55-20
Non Lead 0.125mmPb	RAD-DP-MCF-4330-NLH55-10



Biliary Split Shield with Slit

Biliary Split access drapes are designed for Trans jugular intrahepatic Porto systematic shunt (TIPS) procedures. The drapes are developed to reduce scatter radiation at the source, creating a limited scatter-free zone, thereby reducing harmful ionizing radiation exposure. Drapes are 43x30cm in size and are provided as a box of 10.

Non Lead Bilayer 0.25mmPb	RAD-DP-BSS-4330-NLB61-20
Non Lead 0.25mmPb	RAD-DP-BSS-4330-NLH55-20
Non Lead 0.125mmPb	RAD-DP-BSS-4330-NLH55-10



Femoral Entry Angiopathy with Hole and Slit

Femoral entry angiopathy with hole and slit is designed for transfemoral access: Angiography, Coronary Catheterization. The drapes are developed to reduce scatter radiation at the source, creating a limited scatter-free zone, reducing harmful ionizing radiation exposure. Drapes are 43x30cm in size and are provided as a box of 10.

Non Lead Bilayer 0.25mmPb	RAD-DP-FEA-4330-NLB61-20
Non Lead 0.25mmPb	RAD-DP-FEA-4330-NLH55-20
Non Lead 0.125mmPb	RAD-DP-FEA-4330-NLH55-10

Exciting New Release
Coming Soon

Radiation Protection Eyewear

Why Wear Protective Lenses?

Dr Ziv Haskal, Professor of Radiology and Director of Vascular and Interventional Radiology, New York Presbyterian Hospital-Columbia University New York, issued this advice to fellow interventional radiologists at the SIR 2004 meeting. He presented a small study that suggests interventional radiologists are at risk for posterior subcapsular cataract formation and later talked to *Interventional News*.

Ziv Haskal explained to *Interventional News* how the study investigating posterior subcapsular (PSC) cataract formation in interventional radiologists, conducted in association with Basil Worgul, a professor of radiation biology in ophthalmology and radiology, and ophthalmologist Dr Anna Junk, came about.

"It was a serendipitous event," said Haskal, "a colleague of mine had come to have his eyes looked at because of another medical issue with them and met Dr Basil Worgul, who is a world renown expert in radiation eye injury research. My colleague told me that he had been surprised to have been diagnosed with this (PSC cataract) by Dr Worgul."

Dr Haskal's colleague therefore advised him to get his eyes checked as well, "I went down to meet Basil Worgul, who it turns out is an ophthalmology researcher, but also has an appointment in the department of radiology in my own hospital. He had never heard of an interventional radiologist – like most people – so I talked to him about what we did and we created this study."

Haskal, Worgul and Junk looked for an opportunity to conduct a small study in a timely fashion. This led them to choose to conduct the study during the AIMsymposium in New York. The equipment used by Worgul was a Nidek EAS1000 Scheimpflug and retroillumination camera. "He (Worgul) made peace with moving the unit to the downtown conference, which was kind enough to give us some booth space. Our target was to get 30 physicians with questionnaires and studies on site as a pilot study for a larger study, to try to at least define whether we were in fact an at risk population. We actually had 59 practicing interventional radiologists participate in a couple of days."

According to Haskal, this was a feasibility study to define if there was something to study and, if there was, to give some sense of the size and shape further studies would need to be.

In the 59 interventional radiologists aged between 29 and 62 (median age 35), PSC cataracts were found in five participants and an additional 22 had evidence of PSC changes – opacities in the posterior area of the lens. One interventional radiologist had undergone cataract surgery before being screened in the study.





Case Study: The effectiveness of lead lenses in reducing radiation exposure.

In a series of tests, optically ground prescription lenses of glass, leaded glass, and plastic were exposed to radiations that simulated routine angiography. Radiations transmitted through the lenses were measured. Results showed that plastic provided no protection, regular glass provided moderate protection and high lead content glass reduced radiation transmission by approximately 70%. The leaded glass that Imaging Solutions uses blocks 97% and up to 150kp.

Relatively high doses of radiation can damage the conjunctiva, iris, sclera and blood vessels of the retina. The lens of the eye, however, is the critical site, for it may sustain irreversible damage from a relatively low dose of radiation. Low doses will produce only a temporary reaction in the other ocular structures.

The sensitivity of the lens to radiation is felt to be due to the failure of normal cell replacement. The lens is surrounded by a capsule. On the anterior surface beneath this capsule is a layer of attended or cuboid cells which comprise the epithellum of the lens and allow for normal metabolism of the lens. At the peripheral border or equator of the lens, these cells become progressively elongated and are transformed into the structure of the lens proper. Von Sallman demonstrated that cytologic damage from radiation to the lens consists of a temporary cessation of mitosis, cell death, and occasional abnormal mitosis produce bizarre cells. Because of the enveloping capsule of the lens, these damaged or bizarre cells can't be sloughed but instead are pushed or migrate to the posterior pole of the lens' where early radiation-induced cataract is first clinically manifest. Subsequent changes may also be observed in the anterior pole, with progressive opacification of the cortex eventually forming a mature and non-specific cataract.

Until now the only protective devices have been heavy cumbersome lead goggles. These are generally not used because of inconvenience and discomfort. Commercially available prescription lenses for ordinary glasses are made of either plastic or glass and therefore offer no or inadequate protection. There are two basic types of glass lenses, and these differ significantly in lead content. Ordinary glass lenses called "crown glass" are used by most people. A less common glass, known to opticians as "hi-lite", happens to have relatively high lead content which allows for a thinner lens than would otherwise be required. It is normally used as a substitute for extremely thick lenses.

The below experiment was designed to determine if significant protection from radiation is provided by wearing high lead content glass instead of ordinary glass or plastic lenses.

"An age-related cataract, the thing we think about conventionally, is in the front of the lens," explains Dr Ziv Haskal, Professor of Radiology and Director of Vascular and Interventional Radiology, New York Presbyterian Hospital-Columbia University New York. These happen in the back of the lens, a completely different area. Radiation is not the only thing that causes this, people can have PSC cataracts from diabetes, from steroids etc., which is why it is important to look for these co-factors and the need for a large enough population to eliminate these."

Asked what the natural occurrence of PSC cataracts was, Haskal replied, "That's the tricky thing!" The accepted level under which radiologists are told they have no risk of cataracts is 200 rads (or 2,000 milligray). However, this appears to be a false threshold, and it is more likely to be a continuous spectrum of dosing. According to Haskal, the results of this study "exceed the expected amount for both age of practitioner and what would be expected for a baseline finding. It is more than we expected to find, and that is why made this conclusion where it increased risk."

On future studies, Haskal said, "We have broad ideas, although we do not have grant support yet. We have compiled a team of people with particular expertise around this, including some very well known expert epidermiologists. As a result of this feasibility study, one has agreed to join us in planning the next step. We have some summer research planned, as well to do better dosimetry for a practitioner. In other words, what people are actually getting exposed to at room time so we can do some better modelling of this."



MAVIG



BR126

The BR126 is designed to best protect the user's eyes from scattered radiation from all angles of incidence. This requirement has been effectively addressed in the design of the glasses by means of large-area X-ray protective glazing and two side radiation protection zones that are closely connected to the front lenses.

- The nose pads are flexibly adjustable for an ergonomic and individual fit
- Materials used ensure the greatest possible freedom from allergies
- Shape and material support the avoidance of injury risks
- Easy cleaning and very good resistance to chemical influences (resistance to disinfectants)

BR126

MVG-BR126

MAVIG glasses are manufactured with optical radiation protective glass of the highest quality. Outstanding light transmission and optically faultless vision are guaranteed. Immaculate workmanship and adaptability in each configuration are a must for us. This guarantees eye protection of the highest quality for medical radiation applications.

Specifications

Bridge	Temple	Lens W.	Weight
18 mm	130 mm	55 mm	80 g

Prescription	Plano, Single Vision, Bifocal FT-28, Progressive
Colour	Cocoa/Light Blue, Cocoa/Mandarin, Midnight/Regatta, Sandstone/Orange, Stardust/Curacao,



Cocoa/Light Blue



Midnight/Regatta



Cocoa/Mandarin







Sandstone/Orange



Stardust/Curacao



Specifications

			
Bridge 20 mm	Temple 130 mm	Lens W. 54 mm	Weight 95 g

Prescription	Plano, Single Vision, Bifocal FT-28, Progressive
Colour	Shiny Onyx/Graphit, Shiny Onyx/Bordeaux

BR130

The anatomically optimized design of the BR130 X-ray protection glasses ensures continuous radiation protection – from the nose to the temple.

- Continuous radiation protection
- Optical corrections are feasible for single / multifocal lenses
- Anti-reflective coating on the lenses as standard
- Easy cleaning and very good resistance to chemical influences (resistance to disinfectants)

BR130

MVG-BR130



Shiny Onyx/Bordeaux



Shiny Onyx/Graphit

Specifications

			
Bridge 18 mm	Temple 130 mm	Lens W. 62 mm	Weight 140 g

Prescription	Plano, Single Vision, Bifocal FT-28, Progressive
Colour	Sahara, Flint Stone

BR125

Seamless eye protection: The entire eye rim with the adjoining lateral protection zones is made of the patented leadfree protective material “Trielle”.

- Extended lateral protective zone
- X-ray safety glasses suitable for spectacle wearers
- Allergy-free due to high-quality plastic material
- Super anti-reflective lenses for relaxed, fatigue-free vision
- Easy cleaning and superior resistance against chemical influences (resistance to disinfectants)

BR125

MVG-BR125



Sahara



Flint Stone





9941 Ultralite

The 9941 Ultralite lead glasses come standard with a rubberized nose bridge. These protective eyewear are designed to offer comfort and provide protection for the entire eye area without the need of additional lead side shields. The 9941 glasses are a popular frame and are ideal for those who have a high power prescription. Available in 2 sizes and optional adjustable nose pads for regular sized frame (9941A).

9941 Ultralite

PTM-RE-9941/9941A/994153



Specifications

Bridge	Temple	Lens W.	Weight
22 mm	130 mm	55 mm	64 g

Prescription Plano, Single Vision, Bifocal FT-28, Progressive

Colour Silver, Black, Red, Blue



99 Ultralite

The 99 Ultralites provide a wide area of protection against x-ray. Their high curvature provide adequate lateral protection which eliminates the need for side shields. The 99 comes in 2 sizes and an optional soft rubber nose bridge for additional support and comfort (99R). (Blue only available in regular size and Fuchsia only available in small).

99 Ultralite

PTM-RE-99



Specifications

Bridge	Temple	Lens W.	Weight
15 mm	120 mm	63 mm	63 g

Prescription Plano, Single Vision, Bifocal FT-28, Progressive

Colour Brown, Black, Blue, Silver, Teal, Light Blue, Light Pink, Fuschia



98 Superlite

The 98 Superlite is an ultra light-weight frame designed for comfort. Its high curvature provides enhanced lateral/side protection against x-ray. Rubberized temples provide a secure, comfortable fit.

98 Superlite

PTM-RE-98



Specifications

Bridge	Temple	Lens W.	Weight
15 mm	120 mm	63 mm	63 g

Prescription Plano

Colour Clear Hazel



Circuit

The Circuit lead glasses frame features wrap-around lenses which maximize lateral protection without the use of side shields. Rubberized temples and nose pads provide excellent comfort and grip. The Circuits modern style combined with its optimized functionality ensure long lasting quality and protection.

Circuit

PTM-RE-CIRC



Specifications

Bridge	Temple	Lens W.	Weight
18 mm	135 mm	60 mm	79 g

Prescription	Plano Only
Colour	Silver/Black, Red/Grey, Black/Grey



Onyx

Deep stylistic curves and lenses combine style with lateral x-ray radiation protection. The Onyx frame features a ventilated nose bridge providing grip, reduced fogging, and comfort.

Onyx

PTM-RE-ONYX



Specifications

Bridge	Temple	Lens W.	Weight
19 mm	135 mm	68 mm	71.8 g

Prescription	Plano Only
Colour	Matte Black, Shiny White



Razer

The Razer Lead Glasses boast a sleek design while being a lightweight and durable frame. These protective eyewear feature a ventilated nose bridge, rubberized temples, and wide-angle lenses which maximize comfort and protection from x-ray. The modern style and use of light-weight materials make the Razer an excellent choice for long-procedures.

Razer

PTM-RE-RAZER



Specifications

Bridge	Temple	Lens W.	Weight
17 mm	135 mm	58 mm	62.5 g

Prescription	Plano, Single Vision, Bifocal FT-28, Progressive
Colour	Matte Green, Matte Black, Matte Grey, Matte Blue, Matte Red



Malibu





The Malibu lead glasses frame modernizes the classic wayfarer design and is offered in several tasteful color selections. While not one of the most protective styles for lateral and wide-angle x-ray protection, the Malibu is a stylish option for those requiring basic radiation protection at an affordable price.

Malibu

PTM-RE-MALIB



Specifications

 Bridge	 Temple	 Lens W.	 Weight
20 mm	155 mm	54 mm	68.1 g

Prescription	Plano, Single Vision, Bifocal FT-28, Progressive
Colour	Matte Blue, Matte Black, Matte Brown, Gloss Black



Mako

The Mako lead glasses frame is boat captain approved with its unique patterns and high curve lenses which maximize radiation protection coverage. Integrated side shields equipped with lead strip side shields provide essential lateral x-ray protection.

Mako

PTM-RE-MAKO



Specifications

 Bridge	 Temple	 Lens W.	 Weight
15 mm	130 mm	65 mm	69.3 g

Prescription	Plano Only
Colour	Grey/Green



XGuard

The XGuard lead goggles feature a clear insert, lead strip side shields for lateral coverage, and tasteful color options.

XGuard

PTM-RE-XGUARD



Specifications

 Bridge	 Temple	 Lens W.	 Weight
18 mm	135 mm	58 mm	81.8 g

Prescription	Plano, Single Vision, Bifocal FT-28, Progressive
Colour	Black/Woodgrain, Matte Black



Proguard LeadR

The LeadR Lead Goggles feature a soft, ventilated nose bridge with rubberized temples for premium comfort. Each LeadR eyewear frame comes with the added protection of 0.50mm leaded side shields and the ability to extend that side protection into an additional panel.

Proguard LeadR

PTM-RE-LEADR

Specifications

Bridge	Temple	Lens W.	Weight
14 mm	120 mm	66 mm	112 g

Prescription	Plano Only
Colour	Black, Grey/Pink, Green/Yellow, White/Purple



Comet

Similar to the Proguard LeadR's frame, the Comet Lead goggles are an affordable option providing excellent coverage against x-ray. The Comet's unique side shield configuration allows for lead shielding to be placed on the frame exterior and wrap around the entire lens area, providing a complete seal from scatter radiation.

Comet

PTM-RE-COMET

Specifications

Bridge	Temple	Lens W.	Weight
19 mm	114 mm	59 mm	78.3 g

Prescription	Plano, Single Vision, Bifocal FT-28, Progressive
Colour	Blue, Grey/Orange, Pink



Centrist

The Centrist lead glasses are a rectangular-style, safety frame made from high quality nylon and has permanent extended side shields for added x-ray protection. The sleek black with clear insert frame has an adjustable nosepiece that provides comfort and a secure fit.

Centrist

PTM-RE-CENT

Specifications

Bridge	Temple	Lens W.	Weight
17 mm	140 mm	55 mm	88 g

Prescription	Plano, Single Vision, Bifocal FT-28, Progressive
Colour	Black Crystal



53 Wrap

The 53 wrap is constructed of durable nylon that exhibits superior flexibility while minimizing potential breakage. Its full saddle bridge provides maximum comfort and evenly distributes weight over the nose.

53 Wrap

PTM-RE-53



Specifications

Bridge	Temple	Lens W.	Weight
16 mm	135 mm	58 mm	84 g

Prescription	Plano, Single Vision, Bifocal FT-28, Progressive
Colour	Black, Tortoise



70 Astroflex

The Astroflex Lead goggles feature molded side shielding and are fitted to the brow for increased splash protection. The goggle's temple length and frame angle are adjustable for a uniform custom fit. The model 70s comes with leaded side shields for necessary lateral x-ray coverage.

70 Astroflex

PTM-RE-70S



Specifications

Bridge	Temple	Lens W.	Weight
19 mm	Adjustable	54 mm	88 g

Prescription	Plano, Single Vision, Bifocal FT-28, Progressive
Colour	Clear/Blue



Tugga Baby

Tugga Baby pediatric glasses provide essential protection during medical fluoroscopy and feature a universal fit with its adjustable headband. These eyewear also come with a matching, Tugga baby eyewear case and a microfiber cleaning cloth.

Tugga Baby

PTM-RE-BABY



Specifications

Bridge	Temple	Lens W.	Weight
18 mm	Adjustable	46 mm	42 g

Prescription	Plano
Colour	Pink, Green, Blue







Fitguard Alpha

The Fitguard Alpha fitover is a versatile, high quality nylon frame. Featuring Flexfit technology, the Fitguard's temples can be easily adjusted for a secure, comfortable fit. The Alpha model is ideal for fitting over wide prescription eyewear while still providing a secure and comfortable fit. With the most balanced weight distribution, the Fitguard Alpha is our most popular fitover model. Blacked out side shields provide a streamlined look as well as 0.50mm lead equivalent protection.

Fitguard Alpha

PTM-RE-FGUARDA

Specifications

 Bridge	 Temple	 Lens W.	 Weight
17 mm	145 mm	69 mm	91 g

Prescription	Plano Only
Colour	Matte Black



Fitguard Beta

The Fitguard Beta fitover is a versatile, high quality nylon frame. Featuring Flexfit technology, the Fitguard lead glasses' temples can be benched (adjusted) easily for a secure, comfortable fit. The Beta model is ideal for fitting over standard prescription eyewear with square or rounded lenses. Blacked out side shields provide a streamlined look as well as 0.50mm lead equivalent protection.

Fitguard Beta

PTM-RE-FGUARDB

Specifications

 Bridge	 Temple	 Lens W.	 Weight
18 mm	150 mm	64 mm	108 g

Prescription	Plano Only
Colour	Matte Black







90 Fitover

Designed to fit over prescription eyewear, the 90 fitover lead glasses are an excellent choice for those requiring protection against x-ray and liquid splashes. The large, clear side shields protect the user from lateral exposure while eliminating the "tunnel" effects of lookalikes.

90 Fitover

PTM-RE-90

Specifications

 Bridge	 Temple	 Lens W.	 Weight
14 mm	120 mm	66 mm	88 g

Prescription	Plano Only
Colour	Matte Black



Classic Metal



The Classic Metal lead glasses are a lightweight frame made of optical steel with bronze electroplate. This durable frame comes standard with contoured 0.50mm LE side shields for maximum lateral coverage. Non-slip, silicone nose pads offer easy adjustability and allow the Modern Metal frame to fit a wide variety of face types.

Classic Metal

PTM-008



Specifications

 Bridge	 Temple	 Lens W.	 Weight
19 mm	140 mm	54 mm	64 g

Prescription	Plano, Single Vision, Bifocal FT-28, Progressive
Colour	Gold, Nano Blue



553S Metalite

The model 553 is a metal frame featuring custom fitted 0.50mm lead strip side shields that create a seal to the front lenses for complete lateral coverage. Non-slip, silicone nose pads provide easy adjustability and allow the frame to fit a wide variety of face types.

553S Metalite

PTM-553S

Specifications

 Bridge	 Temple	 Lens W.	 Weight
18 mm	140 mm	50 mm	62 g

Prescription	Plano, Single Vision, Bifocal FT-28, Progressive
Colour	Silver



661 Metalite

The model 661/662S is a metal frame featuring custom fitted 0.50mm lead strip side shields that create a seal to the front lenses for complete lateral coverage. Non-slip, silicone nose pads provide easy adjustability and allow the frame to fit a wide variety of face types.

661 Metalite



PTM-661

661S Metalite - Side Shield

PTM-661S



Specifications

 Bridge	 Temple	 Lens W.	 Weight
18 mm	144 mm	52 mm	70 g

Prescription	Plano, Single Vision, Bifocal FT-28, Progressive
Colour	Gold



Nike Brazen



The Nike Brazen lead glasses feature a ventilated nose bridge for grip, comfort, and reduced fogging. The Brazen's frame is constructed of lightweight nylon and offers superior coverage and protection.

Nike Brazen

PTM-N-BR



Specifications

 Bridge	 Temple	 Lens W.	 Weight
16 mm	140 mm	60 mm	75 g

Prescription	Plano, Single Vision, Bifocal FT-28, Progressive
Colour	Matte Black with Blue, Gloss Black



Nike Premier





The Nike Premier lead glasses offer a diverse selection of colors and tasteful design elements. The Premier protective eyewear feature large rectangular lenses to provide adequate x-ray protection and coverage.

Nike Premier

PTM-N-PRMR



Specifications

 Bridge	 Temple	 Lens W.	 Weight
13 mm	135 mm	60 mm	67.8 g

Prescription	Plano, Single Vision, Bifocal FT-28, Progressive
Colour	Matte Tortoise, Matte Anthracite, Matte Black



Nike Rabid





Designed to fit over prescription eyewear, the 90 fitover lead glasses are an excellent choice for those requiring protection against x-ray and liquid splashes. The large, clear side shields protect the user from lateral exposure while eliminating the "tunnel" effects of lookalikes.

Nike Rabid

PTM-N-RABID



Specifications

 Bridge	 Temple	 Lens W.	 Weight
14 mm	145 mm	63 mm	63 g

Prescription	Plano Only
Colour	Matte Black/ White



Wiley-X P-17

The Wiley-X P-17 lead glasses are low-profile and lightweight, making them a fan favorite. These protective frames boast highly curved lenses for maximum x-ray protection. The P-17 eyewear are ideal for medium to large facial structures.

Wiley-X P-17

PTM-WX-P17

Specifications

			
Bridge	Temple	Lens W.	Weight
18 mm	125 mm	68 mm	84.5 g

Prescription	Plano Only
Colour	Gloss Black, Matte Black, Brown



Wiley-X Brick

The Wiley-X Brick lead glasses offer a flexible rubber temple for support during intense activities while the removable Facial Cavity Seal provides maximum splash protection. These protective eyewear boast highly curved lenses for excellent x-ray protection.

Wiley-X Brick

PTM-WX-BRICK-MBLK

Specifications

			
Bridge	Temple	Lens W.	Weight
19 mm	140 mm	54 mm	64 g

Prescription	Plano Only
Colour	Matte Black, Matte Black with Rx Trim



Full Acrylic Face Shield

The Full Acrylic Face Shield utilizes a lead impregnated acrylic shield suspended from a dual adjustable headpiece. This lead face shield provides additional x-ray protection due to its larger lead impregnated shield. Because of the multi-adjustable headpiece, you can angle the mask to protect from radiation in many different positions as well as adjust the size to comfortably fit your head.

Full Acrylic Face Shield

PTM-450FPM



Panoramic Acrylic Face Shield

The Panoramic Acrylic Face Shield utilizes a lead impregnated acrylic shield suspended from a dual adjustable headpiece. This lead face shield provides additional x-ray protection due to its larger lead impregnated shield. Because of the multi-adjustable headpiece, you can angle the mask to protect from radiation in many different positions as well as adjust the size to comfortably fit your head.

Panoramic Acrylic Face Shield

PTM-400PSM



Mobile Shielding Protection

Mobile protective shields assist you to minimise disturbance, while remaining in-room during procedures. Designed with operational, procedural and personnel demands in mind, our mobile shielding options are ideal for your operational requirements.

Apex Mobile Screen

Mobile radiation protective screens with lead glass viewing panel. Available in four different sizing options, suitable for any environment.

Lead equivalence is 2.1 Pb.

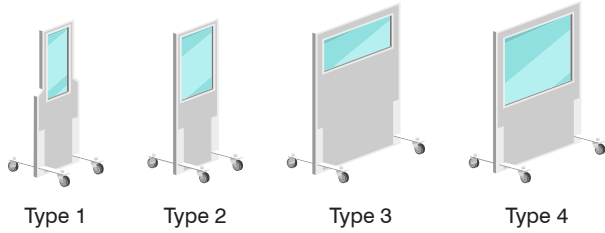

Type	Overall Dimensions	Window Dimensions	Product Code
Type 1	600W x 2000H x 650D mm	330 x 1000 mm	RAD-SH-A060-W033X100-TP
Type 2	600W x 2000H x 650D mm	400 x 1000 mm	RAD-SH-A060-W040X100
Type 3	1200W x 2000H x 650D mm	1000 x 500 mm	RAD-SH-A120-W100X050
Type 4	1200W x 2000H x 650D mm	1000 x 1000 mm	RAD-SH-A120-W100X100
Type 5	600W x 2000H x 650D mm	None	RAD-SH-A060-W0
Type 6	1200W x 2000H x 650D mm	None	RAD-SH-A120-W0

Zenith Mobile Screen

Powder coated steel frames, precision TIG welded for years of trouble-free service completely enclosing the leaded glass panel for increased durability and safety. Includes extra support around base.

Lead equivalence is 2.1 Pb.

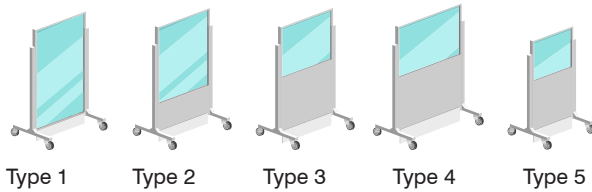

Type	Overall Dimensions	Window Dimensions	Product Code
Type 1	1100W x 1975H x 768D mm	1000 x 1800 mm	RAD-SH-Z110-W100x180
Type 2	1100W x 1975H x 768D mm	1000 x 1330 mm	RAD-SH-Z110-W100x133
Type 3	1100W x 1975H x 768D mm	1000 x 1000 mm	RAD-SH-Z110-W100x100
Type 4	1300W x 1975H x 768D mm	1200 x 1000 mm	RAD-SH-Z130-W120x100
Type 5	760W x 1975H x 768D mm	660 x 1000 mm	RAD-SH-Z076-W066x100



Angled H-Base



X-Base

Zenith Personal Mobile Screen

Height adjustable mobile personal shield, featuring a RADsafe protective panel supported by a powder coated steel frame with precision TIG welds and medical grade wheels for years of trouble-free service.

Lead equivalence is 0.5 Pb.

Unique shield design for todays users, featuring:

- Angled H Base improving usability and handling
- Also Available with X Base
- Centralised height adjustment allowing no obstructions above the shield
- Middle mount support allowing ease of left hand, right hand or both
- Medical grade castors (wheels) as standard
- RADsafe lead protective panel as standard



Zenith Personal - X-Base Screen	RAD-SH-ZP-XB
Zenith Personal - Angled H-Base Screen	RAD-SH-ZP-HB

Specifications:

- Shield Size: 1120x500mm
- Shield Protection: 0.5mmPb RADsafe Non-Lead Bilayer
- Frame Width: 840mm at user side, 240mm at patient side
- Frame Depth: 520mm
- Frame Height: 1225mm at lowest, 1710mm at highest
- Height Adjust: Manual pull pin, release, lift and lock

Custom Sizes and Configurations
Available on Request



Find your compatible RADprotect™ splash drape over page.



RADprotect™ Splash Drapes

Designed to fit popular models of personal radiation shields, the RADprotect™ splash drapes are available in a wide range of shapes and sizes. The splash drapes are used extensively in areas which are designated as sterile environments and typically include theatres, catheter labs, hybrid areas, and radiology centres.

Splash drapes have proven to be extremely useful for protecting over-table and under-table radiation shields. The radiation shields are supplied in a wide range of shapes and sizes to suit individual OEM beds and surgeon configuration preferences, which are routinely near both the patients and surgeons during procedures. By utilizing the plastic splash drapes, the risk of exposure to potential contamination is reduced.

Portable radiation shields can also be protected as they are also regularly utilised in the interventionalist environments and near interventionalist activity when used by scout nurses and other in-room technologists and clinicians involved in procedures.

Available in multiple sizes and made of 37µm recyclable LDPE the splash drapes are sterilised via irradiation treatment to AS4187 specifications to ensure optimum protection.



The table below is a list of Imaging Solutions current RADprotect™ splash drapes available, the dimensions and sku codes. Imaging Solutions has developed these specific range of plastic splash drapes to accommodate for standard radiation protection shields found commonly in hospitals. The various sizes have been developed to fit over a range of standard rectangle radiation shields as shown in the tables below, with more design being made available soon to fit contoured models, overhead shields, and ceiling mounted plates.

Features

- Designed to fit a wide range of personal radiation shields.
- Versatile usage across sterile environments such as theatres, catheter labs, hybrid areas, and radiology centres.
- Protects both over-table and under-table radiation shields, reducing exposure to potential contamination.
- Suitable for various OEM beds and surgeon configuration preferences, enhancing convenience and efficiency.
- Constructed from 37µm recyclable Low-Density Polyethylene (LDPE), promoting sustainability.
- Sterilised using irradiation treatment to meet AS4187 specifications, ensuring high-grade, optimal protection.

Compatible Shield Sizes	Dimensions	Product Code
500mm wide short shields	RADprotect™ Splash Drape 700 x 1200mm (Box of 50)	RAD-PT-070120
500-600*mm wide shields	RADprotect™ Splash Drape 800 x 1750mm (Box of 50)	RAD-PT-080175
500-600mm wide shields	RADprotect™ Splash Drape 900 x 1750mm (Box of 50)	RAD-PT-090175
900-1000mm wide shields	RADprotect™ Splash Drape 1300 x 1750mm (Box of 50)	RAD-PT-130175
1000-1100mm wide shields	RADprotect™ Splash Drape 1400 x 1750mm (Box of 50)	RAD-PT-140175
1100-1200mm wide shields	RADprotect™ Splash Drape 1500 x 1750mm (Box of 50)	RAD-PT-150175
1200-1300mm wide shields	RADprotect™ Splash Drape 1600 x 1750mm (Box of 50)	RAD-PT-160175
See compatibility matrix	RADprotect Splash Drape 81 x 95cm Cover Band Nose Shaped (Box of 50)	RAD-PT-081095-BN
See compatibility matrix	RADprotect Splash Drape 89 x 120cm Cover Band Nose Shaped (Box of 50)	RAD-PT-089120-BN

RADshield™ and RADprotect™ Compatibility Table

Shield		RADprotect™	
RADshield™ Apex™ Mobile Screen			
RAD-SH-A060-W033X100-TP	600 x 2000mm	RAD-PT-080175	80 x 175cm
RAD-SH-A060-W040X100	600 x 2000mm	RAD-PT-090175	90 x 175cm
RAD-SH-A060-W0	600 x 2000mm	RAD-PT-090175	90 x 175cm
RAD-SH-A120-W100X050	1200 x 2000mm	RAD-PT-150175	150 x 175cm
RAD-SH-A120-W100X100	1200 x 2000mm	RAD-PT-150175	150 x 175cm
RAD-SH-A120-W0	1200 x 2000mm	RAD-PT-150175	150 x 175cm
RADshield™ Zenith™ Mobile Screen			
RAD-SH-Z110-W100x180	1100 x 1975mm	RAD-PT-140175	140 x 175cm
RAD-SH-Z110-W100x133	1100 x 1975mm	RAD-PT-140175	140 x 175cm
RAD-SH-Z110-W100x100	1100 x 1975mm	RAD-PT-140175	140 x 175cm
RAD-SH-Z130-W120x100	1300 x 1975mm	RAD-PT-160175	160 x 175cm
RAD-SH-Z076-W066x100	760 x 1975mm	RAD-PT-090175	90 x 175cm
RADshield™ Zenith™ Personal Screen			
RAD-SH-ZP-XB	500 x 1120mm	RAD-PT-070120	70 x 120cm
RAD-SH-ZP-HB	500 x 1120mm	RAD-PT-070120	70 x 120cm
MAVIG Overtable Shields			
MVG-OT50001*	600 x 760mm	RAD-PT-081095-BN	81 x 95cm
MVG-OT90001*	600 x 760mm	RAD-PT-081095-BN	81 x 95cm
MVG-OT54001*	780 x 900mm	RAD-PT-089120-BN	89 x 120cm
MVG-OT94001*	780 x 900mm	RAD-PT-089120-BN	89 x 120cm
Kenex Overtable Shields			
KNX-351/P/76-001	610 x 760mm	RAD-PT-081095-BN	81 x 95cm





Mobile Leaded Barrier, LB-2430

Mobile Leaded Barrier LB-2430 with 24" x 30" Window is a portable, full-body radiation barrier for protection against secondary radiation.

Features:

- 2.0mm Lead equivalent opaque panels of solid, leaded x-ray protection with contoured sides
- Large 24" x 30" window for easy viewing. The window offers a material choice of:
 - » 2.0mm lead equivalent high quality Schott leaded glass
 - » 0.50mm lead equivalent lighter weight leaded acrylic

Overall size	75 (h) x 33.5 in (w)
Window pane	24 (h) x 30 in (w)
Opaque panel	48 (h) x 30 in (w)
Shipping weight approx.	110 lb

Mobile Leaded Barrier, Acrylic PSP-LB-2430-ACR

Mobile Leaded Barrier, Glass PSP-LB-2430-LSG



Mobile Leaded Barrier, LB-3048

Mobile Leaded Barrier LB-3048 with 30" x 48" Window is a portable, full-body radiation barrier for protection against secondary radiation.

Features:

- 2.0mm Lead equivalent opaque panels of solid, leaded x-ray protection with contoured sides
- Large 30" x 48" window for easy viewing. The window offers a material choice of:
 - » 2.0mm lead equivalent high quality Schott leaded glass
 - » 0.50mm lead equivalent lighter weight leaded acrylic

Overall size	75 (h) x 33.5 in (w)
Window pane	48 (h) x 30 in (w)
Opaque panel	22 (h) x 30 in (w)
Shipping weight approx.	225 lb

Mobile Leaded Barrier, Acrylic PSP-LB-3048-ACR

Mobile Leaded Barrier, Glass PSP-LB-3048-LSG



Mobile Leaded Barrier, LB-3060

Mobile Leaded Barrier LB-3060 with 30" x 60" Window is a portable, full-body radiation barrier for protection against secondary radiation.

Features:

- 2.0mm Lead equivalent opaque panels of solid, leaded x-ray protection with contoured sides
- Large 30" x 40" window for easy viewing. The window offers a material choice of:
 - » 2.0mm lead equivalent high quality Schott leaded glass
 - » 0.50mm lead equivalent lighter weight leaded acrylic

Overall size	75 (h) x 33.5 in (w)
Window pane	60 (h) x 30 in (w)
Opaque panel	12 (h) x 30 in (w)
Shipping weight approx.	450 lb

Mobile Leaded Barrier, Acrylic PSP-LB-3060-ACR

Mobile Leaded Barrier, Glass PSP-LB-3060-LSG



Tilted Mobile Leaded Barrier, LB-2430-B

Tilted Mobile Leaded Barrier with 24" Window LB-2430-B

Features:

- Tilted 30 degree window panel
- 2.0mm Lead equivalent opaque panels of solid, leaded x-ray protection with contoured sides
- Large 24" x 30" window for easy viewing. The window offers a material choice of:
 - » 2.0mm lead equivalent high quality Schott leaded glass
 - » 0.50mm lead equivalent lighter weight leaded acrylic

Overall size	70" H x 34" W X 25" L
---------------------	-----------------------

Window pane	24 (h) x 30 in (w)
--------------------	--------------------

Tilted Mobile Leaded Barrier, Acrylic	PSP-LB-2430-B-ACR
--	-------------------

Tilted Mobile Leaded Barrier, Glass	PSP-LB-2430-B-LSG
--	-------------------



Mobile Leaded Barrier with Window, LB-3648

Mobile Leaded Barrier with 30" x 48" Window

Features:

- 2.0mm lead equivalent opaque panels of solid, leaded x-ray protection with contoured sides
- Window material choice of:
 - » 2.0mm lead equivalent high quality Schott leaded glass
 - » 0.50mm lead equivalent leaded acrylic

Overall size	75 (h) x 52.5 in (w)
---------------------	----------------------

Window pane	30 (h) x 48 in (w)
--------------------	--------------------

Opaque panel	36 (h) x 48 in (w)
---------------------	--------------------

Mobile Leaded Barrier, Acrylic	PSP-LB-3648-ACR
---------------------------------------	-----------------

Mobile Leaded Barrier, Glass	PSP-LB-3648-LSG
-------------------------------------	-----------------



Mobile Leaded Barrier, LB-1224

Mobile Leaded Barrier 1224 is manufactured in-house of the highest quality materials and craftsmanship. Product Specifications:

Features:

- 2.0mm Pb, Lead Glass window 12" x 24"
- Overall dimensions: 74" H x 52½" W X 25" D
- Supported by steel legs with heavy duty smooth rolling casters

Overall size	12 (h) x 24 in (w)
---------------------	--------------------

Mobile Leaded Barrier	PSP-LB-224
------------------------------	------------



Collapsible Mobile Leaded Barrier, LB-7429

Collapsible Mobile Leaded Barrier is a portable, full-body radiation barrier for protection against secondary radiation.

Features:

- A screen that can be easily raised and lowered by hand
- 0.50mm lead equivalent light weight leaded acrylic window
- 2.0mm lead equivalent steel and lead frame

Overall size	70 (h) x 31 in (w)
Shipping weight approx.	170 lb

[Collapsible Mobile Leaded Barrier, LB-7429](#)

PSP-LB-7429



Deluxe Mobile Lead Shield (30" L x 24" W) on T-Base

Accommodating shielding for both children and adults. Adjustable height mobile shield that adjusts from 8" to 60" are excellent for patient and staff protection during imaging procedures. All steel T-Base provide excellent stability and confidence in no-tipping. Easy movement around the room and the unique base allows easy positioning around equipment and wall stands. Posi-Lock height adjustable arm with spring-loaded pin.

Made of durable nylon fabric and 0.5mm or 1.0mm Pb equivalency protection. Several sizes available with this unique base. One year warranty. Quick and easy assembly.

Note: Shield measures 30" Long x 24" Wide, with grommets along the top 24" edge

[Deluxe Mobile Lead Shield on T-Base Shield](#)

PSP-LB-MB-3024-TB



Max Mobile Lead Shield with H-Base

- 0.5mm Pb equivalency
- Adjustable height: up to 60"
- Post Height: 60"
- Base Overall Dimensions: 24" W x 24" D
- H Base Inside Dimensions: 20" W x 16" D
- All steel H-base for maximum stability. Hardened chrome steel post.
- Posi-Lock height adjustable arm with spring-loaded pin.

[Max Mobile with H Base Shield 36" x 36"](#)

PSP-LB-MB-3636

[Max Mobile with H Base Shield 48" x 48"](#)

PSP-LB-MB-4848

Mavig Mobile Shields

Moveable Protective Shields for Flexible Use

MAVIG produces mobile shields from the most modern protective material in a variety of options. All requirements of equipment and procedural methodology of the operation room, as well as all demands of the personnel have been taken into consideration. We of course welcome specific needs of our clients in addition to our standard offerings.

With exception to models WD254, WD255, and WD258, all of our mobile shields are fitted with special wheels to reduce electrostatic electricity.



Lower Body Mobile X-Ray Shield

The compact, anatomically formed shield of the model WD261 allows for a close body fit so that the doctor can move freely throughout the procedure. Due to springs the user can adjust the height of the shield to his own height or working position requested, at any time i.e. also during the procedure.

The shield was designed to offer sufficient legroom in order to eliminate any risk of injury. The unimpeded use of the control pedal of the x-ray unit accounts for another advantage.

- Height adjustable for individual needs from 1050 to 1350 mm
- Lead equivalent 0.50 mm Pb
- Easy to clean outer material: MAVIG ComforTex®-HMPF
- Designed for easy and comfortable control pedal use
- High quality, electrically conductive wheels with brakes
- Specially designed sterile covers MVG-STEAWD261 to meet strict hospital hygienic regulations

Protection	Height adjustable 1060 to 1360 mm
Lead equivalency	0.50 Pb

MVG-WD261 Mobile Lower Body Shield

MVG-WD261





Adjustable Mobile X-Ray Shield

Sleek construction and stable base legs save space and ensure safety. A classic model in interventional radiology, the lead acrylic glass panel is easily adjusted and retracts inside its steel base.

Protection	Steel body (78 cm width, 107 cm height); lead acrylic glass (70 cm width)
Overall height	Adjustable from 115 cm to 188 cm
Lead equivalency	0.50 Pb (Lead acrylic glass) 1.0 Pb (Steel body);

WD257 Adjustable Mobile Shield MVG-WD2571



Contoured Mobile X-Ray Shield

The out-adjustable shield with contour cut can be placed over the body of the patient effectively reducing secondary radiation emanating from the patient's body.

The MVG-WD304 mobile radiation protection has the same characteristics as the MVG-WD302 shield. In addition, it offers an under table protection consisting of flexible overlapping radiation protective strips with a lead equivalency of 0.50 Pb.

Protection	Steel body (77.5 cm width, 79 cm height); lead acrylic glass (70/110 cm width); strips (50 cm width, 64 cm height)
Overall height	Adjustable from 143 cm to 190 cm
Lead equivalency	Steel body (1.0 Pb); lead acrylic glass (0.50 Pb)

Contoured Mobile Shield MVG-WD3021

Contoured w/ Lower Body Panel MVG-WD3041



Mobile X-Ray Protective Shield

The mobile protection screen WD204, available in different widths, consists of an upper part with transparent lead glass and a lower protective part.

- Light weight aluminum frame construction
- MAVIG lead glass with excellent light transmission

Overall width	700 to 1700 mm
Overall height	1950 mm
Window width	Available from 360 mm to 760 mm
Window height	460 mm
Lead Equivalent	Available in 0.50 mmPb or 2.00 mmPb (Window is always 2.00 mmPb)

Mobile X-Ray Protective Shield MVG-WD204



Mobile X-Ray Protective Shield

The WD504, available in different widths, with the large lead glass screen provides maximum protection with a clear view for personnel. Mobile protection screen in lightweight aluminium construction, with lead glass window.

- Easy and simple positioning
- MAVIG lead glass with excellent light transmission
- Light weight aluminum frame construction

Overall width	700 to 1700 mm
Overall height	1950 mm
Window width	Available from 800 mm to 1700 mm
Window height	784 mm
Lead Equivalent	Available in 0.50 mmPb or 2.00 mmPb (Window is always 2.00 mmPb)

Mobile X-Ray Protective Shield MVG-WD504



Curved Mobile Shield

The slightly curved lead acrylic shield is suited to the body's shape and offers maximum mobility. The unique shield is especially suited for applications in interventional radiology. The form and height of the cutouts can be ordered to meet individual requirements.

Protection	Curved lead-acrylic shield with side arm cutouts (82 x 190 cm)
Lead equivalency	0.50 Pb
MVG-WD300 Curved Mobile Shield	

MVG-WD300



Spatial Mobile X-Ray Shield

The MVG-WD306 Mobile Spatial Shield model is optimally designed for spatial shielding. Available in larger widths to meet customer requirements. The mobile lower body protection is used when under table radiation protection is required, although the table does not offer any option for accessory rails.

Protection	100 x 187 cm or 130 x 187 cm
Lead equivalency	0.50 Pb / 1.0 Pb
MVG-WD306 (100x187 cm, 0.50 Pb)	MVG-WD306/0.5/1000
MVG-WD306 (130x187 cm, 0.50 Pb)	MVG-WD306/0.5/1300
MVG-WD306 (100x187 cm, 1.0 Pb)	MVG-WD306/1.0/1000
MVG-WD306 (130x187 cm, 1.0 Pb)	MVG-WD306/1.0/1300



Mobile Lower Body Shield

Used for under table protection, although the table does not offer any option for accessory rails.

Overlapping flexible strips ensure optimal protection and extend operating range. The sleek and manoeuvrable system is statically secure and offers lots of space. High variability due to a removable shield. The stable base offers a large operating range with very little space required.

Protection	1 or 2 removable upper pieces (170 mm and 250 mm in height); middle section (60 x 100 cm); 2 angled side sections (20 x 100 cm)
Lead equivalency	0.50 Pb
MVG-WD260 Mobile Lower Body Shield	

MVG-WD260



Mobile Bed Screen

The mobile bed screens can easily be moved by anyone, especially helpful in neo-natology or intensive care wards. This versatile screen efficiently reduces exposure to secondary radiation. A spring-driven support simplifies height adjustment. The Mavig protective material is flexible, which prevents damage, even in case of collisions.

Shield (90 x 70 cm); height adjustable from 128 cm to 172 cm

MVG-WD258 Mobile Bed Screen	MVG-WD258
------------------------------------	-----------

Kenex quality and innovation in medical products.

A commitment to protective medical devices of outstanding quality and effectiveness has helped establish Kenex among the world's leading suppliers. Attention to detail is applied at every stage of the process, from product development, right through to final despatch.



303 – Mobile protective shield

Solid panel design: 2.24 mm lead core face in plastic laminate edged in satin aluminium with 2 mm Pb equivalent clear lead glass window.

Standard mobile shields

Fitted with 30 cm high x 40 cm wide window

Description	Product Code
Standard shield 200 cm high x 75 cm wide	KNX-303/B2/75
Standard shield 200 cm high x 90 cm wide	KNX-303/B2/90

Panoramic mobile shield

Fitted with 60 cm high x 90 cm wide window

Description	Product Code
Panoramic shield 200 cm high x 90 cm wide	KNX-303/B3/90



310/B-3 – Height adjustable mobile protective shield



Original Kenex design exceeds the demands of professionals.

- Ideal for use in confined areas close to the table side.
- The counterbalanced lead acrylic window can be raised in an instant or lowered to gain access to the patient.
- Optional full width rail can be used for equipment hand controls.
- Occupies very little space when not in use.

Window: 70 cm wide (0.5 mm Pb equivalent):

Height range: 115 - 188 cm.

Lower steel panel: 78 cm wide (1.0 mm Pb equivalent).

Height adjustable mobile protective shield

KNX-310/B-3

317 – Flexible protective side panel

A flexible curtain on a double-jointed pivotal arm can be factory fitted to the side, or to both sides of the above mobile shield model 310/B-3.

- One curtain, when fully extended increases the shield width by 68 cm.
- Pivotal arm and curtain can swivel round to form a curved side wing.
- Flexible 0.5 mm curtain is 85 cm long.
- Curtain folds across the front when not in use.

Protective side panel (per side)

KNX-317/05-01



326/05 – Height adjustable over-table protective shield

A dramatic reduction in radiation exposure to the whole body can be achieved when this mobile x-ray shield is properly utilised. It creates an extensive safety zone within which the practitioner can work. The wide shadow cast by the shield also provides protection to assisting personnel. This mobile shield combines all the attributes of overhead-suspended shields and table mounted shields in a single unit, without the need for installation.

Protection	45-80 x 139-169 cm
Lead equivalency	0.50 Pb

326/05 Adjustable Over-Table Mobile Shield

KNX-326/05



314/05 – Flexible panel mobile shields

Mobile panel is height adjustable with spring assistance.

- Height range: 85 cm to 120 cm.
- Single flexible panel model is 70 cm wide x 60 cm high.
- Double panel version has fixed extra protection below.
- Lead equivalent: 0.5 mm.

Protection	60-70 x 85-120 cm
Lead equivalency	0.50 Pb

Single flexible panel mobile shield

KNX-314/05-01

Double flexible panel mobile shield

KNX-314/05-02

Lower Body Shielding

Modular Lower Body Protection for Multiple Applications

Both the user and the assistant benefit from the innovative, large-area lower body scatter radiation protection (below the table). An accessory rail that is mounted on the lower body guard also provides the necessary space for table and C-arm control units, as well as other equipment.

Example: MVG-UT70 with maximum possible protective surface (MVG-UT70-90NSWS) Lower body protection for and with 9 x 25 mm accessory rail, total width up to 1620 mm consisting of: 1x main part (MS), 1x wide side panel (WS), 1x narrow side panel (NS), plus two matching detachable attachment shields (1x wide and 1x narrow)



MVG-UT70-xxnSWS



MVG-UT70-xxnS



MVG-UT70-xxnSnS



MVG-UT70-xxWS

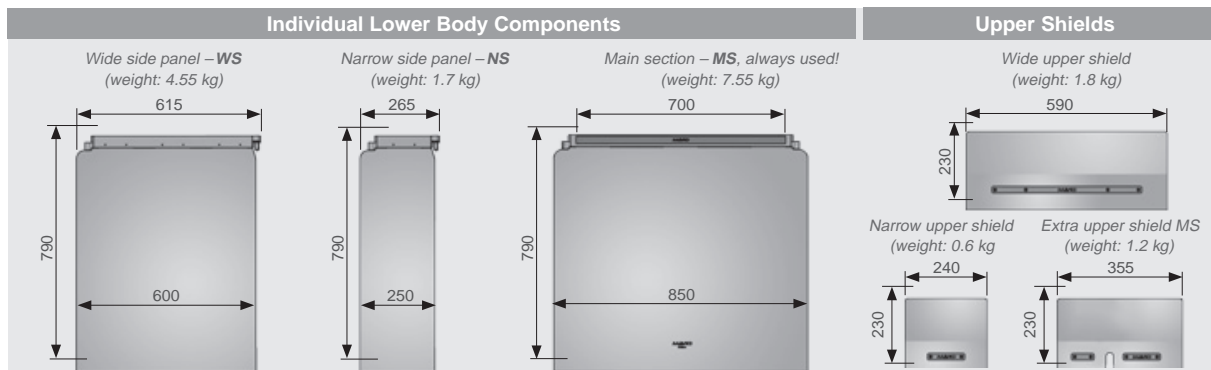

Description

Product Code

Lower body protection MVG-UT70 with 7.7 mm accessory rail - MS, NS, WS	MVG-UT70-77NSWS
Lower body protection MVG-UT70 with 9 mm accessory rail - MS, NS, WS	MVG-UT70-90NSWS
Lower body protection MVG-UT70 with 10 mm accessory rail - MS, NS, WS	MVG-UT70-10NSWS
Lower body protection MVG-UT70, main section only with 7.7 mm accessory rail - MS	MVG-UT70-77
Lower body protection MVG-UT70, main section only with 9 mm accessory rail - MS	MVG-UT70-90
Lower body protection MVG-UT70, main section only with 10 mm accessory rail - MS	MVG-UT70-10
Lower body protection MVG-UT70, 2 parts, with 7.7 mm accessory rail - MS, NS	MVG-UT70-77NS
Lower body protection MVG-UT70, 2 parts, with 9 mm accessory rail - MS, NS	MVG-UT70-90NS
Lower body protection MVG-UT70, 2 parts, with 10 mm accessory rail - MS, NS	MVG-UT70-10NS
Lower body protection MVG-UT70, 3 parts, with 7.7 mm accessory rail - MS, NS, NS	MVG-UT70-77NSNS
Lower body protection MVG-UT70, 3 parts, with 9 mm accessory rail - MS, NS, NS	MVG-UT70-90NSNS
Lower body protection MVG-UT70, 3 parts, with 10 mm accessory rail - MS, NS, NS	MVG-UT70-10NSNS
Lower body protection MVG-UT70, 2 parts, with 7.7 mm accessory rail - MS, WS	MVG-UT70-77WS
Lower body protection MVG-UT70, 2 parts, with 9 mm accessory rail - MS, WS	MVG-UT70-90WS
Lower body protection MVG-UT70, 2-part, with 10 mm accessory rail - MS, WS	MVG-UT70-10WS
Wide upper shield, single - WS	MVG-E-UT70U030
Narrow upper shield, single - NS	MVG-E-UT70U050
Extra upper shield for main shield, single - MS	MVG-E-UT70U080
Wall mount for main section - MS	MVG-E-UT70W010
Wall mount for wide and narrow side panel(s) - NS, WS	MVG-E-UT70W020

Lower Body Shields

MVG-UT6030 / MVG-UT6031 / MVG-UT6032 – Lower Body Protection System

The lower body protection system has a stable construction, rounded edges for low injury risks and a significantly larger protection zone against X-ray radiation scattering for the examiner and the assistant. Flexible, overlapping panels are more comfortable for the examiner and allow undisturbed movement of the C-arm. The pivoting panels adjust to a possible tilt of the table of up to 15°.

- Double-jointed adapter with 290 mm wide additional panel for flexibility
- Upper table scatter radiation attachment shield for the 500 mm wide lower
- Optimised surfaces for thorough and time-saving hygiene
- Lead equivalent of 0.50 mm Pb for each protection component
- Suitable for table rails with profiles from 7 x 25 mm to 10 x 30 mm
- Additional 460 mm long accessory rail (MVG-UT6030: 7.7 x 25 mm, MVG-UT6031: 9 x 25 mm or MVG-UT6032: 10 x 25 mm), e.g. for mounting control elements up to a maximum of 15.0 kg
- Dimensions of MVG-UT60xx:
Height with upper shield: 1,100 mm (without upper shield 900 mm)
Main section 885 x 540 mm (H x W; three overlapping panels)
- Total weight: 21.7 kg (with upper shield)
- Including wall mountings (1x for 500 mm wide lower part, 1x for upper shield)

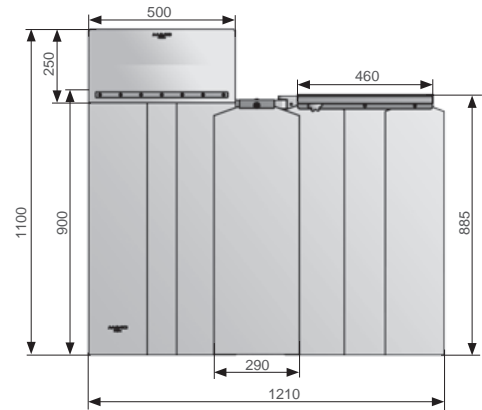

Description

Product Code

Lower body protection model 6030 with 460 mm accessory rail (GE, profile: 7.7 x 25 mm)	MVG-UT6030
Lower body protection model 6031 with 460 mm accessory rail (Toshiba/Canon, profile: 9 x 25 mm)	MVG-UT6031
Lower body protection model 6032 with 460 mm accessory rail (Philips/Siemens, profile: 10 x 25 mm)	MVG-UT6032
Lower body protection model for China with 460 mm accessory rail (profile: 7.7 x 25 mm)	MVG-UT6001-66

Lower Body Protection System

The MVG-UT69 offers maximum protection thanks to the intermediate double articulated joint and additional protection panel. The upper shield can be removed quickly in case of emergency or for comfortable patient positioning.

- Overlapping, flexible radiation protective panels with PVC covering
- Lead equivalent of 0.50 mm Pb / total weight: MVG-UT6902 = 27.9 kg ; MVG-UT6904 = 26.9 kg
- Height without upper shield: 900 mm, width: 645 mm (main section, 4 overlapping panels) 170 mm (additional panel)
- Total width of all lower body protection panels (below the table): max. 800 mm (overlapping, adjustment angle)
- Universal adapter: suitable for table rails ranging from 7 x 25 mm to 10 x 30 mm
- Two separate upper shields (depending on model), resp. 170/250 mm in height; width: 600 mm
- Includes wall mounts (1 x main section and 1 x upper shield)

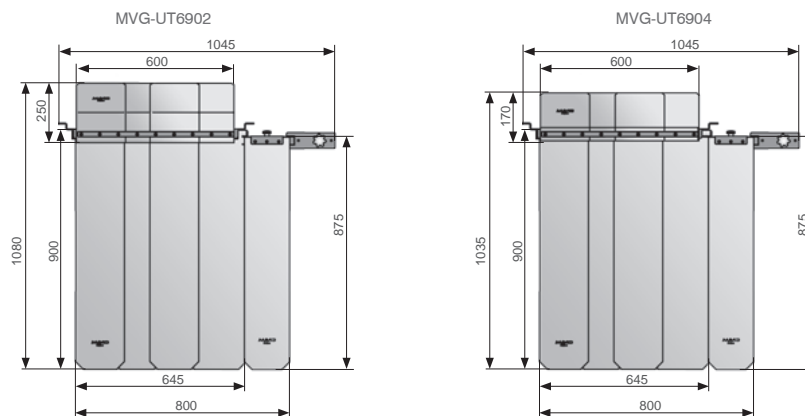

Description

Product Code

Lower body protection model 6269, two matching, removable upper shields (170 + 250 mm)	MVG-UT6901
Lower body protection model 6269, one matching, removable upper shield (250 mm)	MVG-UT6902
Lower body protection model 6269, one matching, removable upper shield (170 mm)	MVG-UT6904

Lower Body Protection System

The MVG-UT6001 is MAVIG's table-mounted radiation shield with freely suspended panels for tilting tables up to 15°. The double-jointed adapter for the table rail enables the user to have a position very close to the table. The MVG-UT6001 has been designed so that it can be placed on either side of the table, thus permitting more versatile application possibilities.

The lower body protection system has been equipped with the universal adapter from MAVIG and therefore fits all table rails with profiles from 7 x 25 mm to 10 x 30 mm.

- Overlapping, flexible radiation protection panels with PVC covering
- Can be mounted on both sides of the table (mirror image)
- Lead equivalent of 0.50 mm Pb
- Dimensions of the MVG-UT6001:
Main section 900 x 500 mm (H x W; three overlapping panels)
Upper shield 250 x 500 mm (H x W)
Additional panel 290 mm (W)
- Total weight: 16.5 kg
- Includes wall mounts (1x for main section and 1x upper shield)

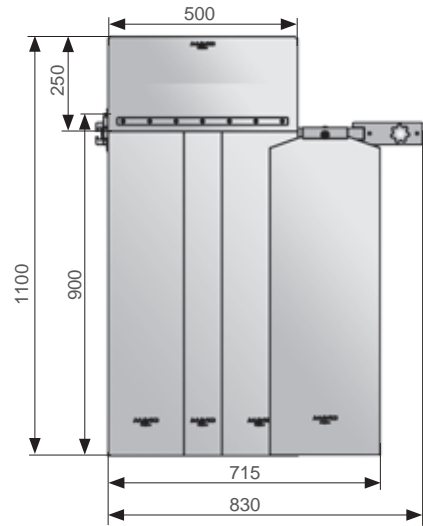

Description

Lower body protection with universal adapter, suitable for accessory rails from 7 x 25 mm to 10 x 30 mm

Product Code

MVG-UT6001

Radiation Protective Panels

MVG-UT30 - Individual, Modular Lower Body Protection System

The MVG-UT30 fills a gap in radiation protection for surgical tables. The uniform panels can be combined and strategically placed to meet different applications and protection needs. The lightweight panels are especially suitable for surgical tables with height adjustable segments.

- Lead equivalent of 0.50 mm Pb
- Length/weight of protection panel:
600 mm / 1.55 kg, 750 mm / 1.75 kg and 900 mm / 1.95 kg
- Width of a single panel: 290 mm (overlap of at least 20 mm recommended)
- Suitable for flat section panels ranging from 7 x 25 mm to 10 x 30 mm
- Panels should be placed to create an overlapping effect



Description

The basic set contains 3 panels, each 600 x 290 mm (L x W), 0.50 mm Pb
 The basic set contains 3 panels, each 750 x 290 mm (L x W), 0.50 mm Pb
 The basic set contains 3 panels, each 900 x 290 mm (L x W), 0.50 mm Pb
 Single panel, 600 x 290 mm (L x W) for adding to and extending a set, 0.50 mm Pb
 Single panel, 750 x 290 mm (L x W), for adding to and extending a set, 0.50 mm Pb
 Single panel, 900 x 290 mm (L x W), for adding to and extending a set, 0.50 mm Pb

Product Code

MVG-UT3060SET
 MVG-UT3075SET
 MVG-UT3090SET
 MVG-UT3060SL
 MVG-UT3075SL
 MVG-UT3090SL

Lower Body Protection System

MAVIG's MVG-UT5001-SI offers ideal protection, especially in the gastroenterological working environment. For the first time, examiners and medical staff can carry out their work unhindered but protected at the same time. The lower protective shield consists of freely suspended, overlapping radiation protection panels which can be easily aligned vertically up to a table inclination of 15°.

The new multifunctional handles make it easy to carry, position and attach the lower body protection. The various attachment shields of the MVG-UT5001-SI can be combined and individually arranged to meet a wide range of interventional applications and protection needs. To facilitate uncomplicated patient positioning and in an emergency, the attachment shields can be removed as quickly as possible.



- Special frame for attaching the MVG-UT5001-SI to the Siemens Artis zee multi-purpose table
- Wide lower body side panel that can be fitted on both sides for large-area protection
- Front panel can be mounted on the front side below the table for extended protection
- Add-on attachment shields, 2 x short & 2 x long, for individual positioning
- Overlapping, flexible radiation protective panels with PVC covering
- Lead equivalent of 0.50 mm Pb
- Includes wall mounts (2 x upper and 2 x lower part)

Wide side panel
(weight: 9.8 kg)

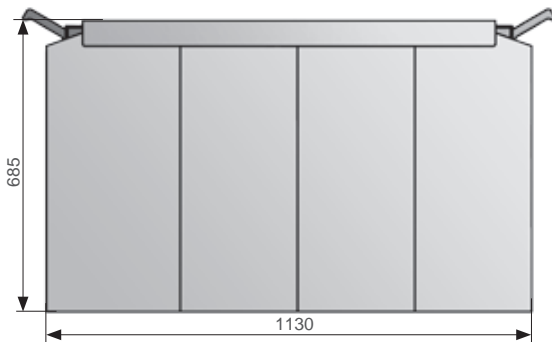

Narrow front panel
(weight: 6.3 kg)

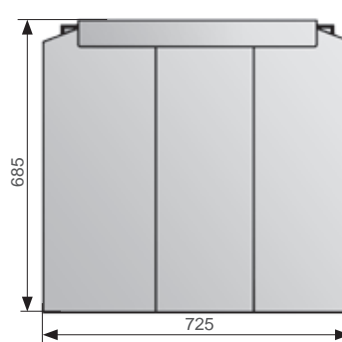

Wide upper shield - front
(weight: 3.2 kg)

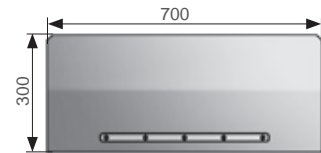

Narrow upper shields - side, 2x each
(weight: 0.6 kg / 0.8 kg)

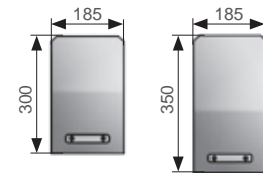

Description

Lower body protection model, for adaptation to Siemens Artis-zee multi-purpose tables by means of a special frame construction, one wide side panel (below the table) and one wide front panel each, including matching add-on attachment shields (1x front, 4x side)

Product Code

MVG-UT5001-SI

Table mounted lower body shields

Shields have either a double-jointed pivotal arm or a single friction pivotal arm. Both can be moved laterally towards the patient or swivelled away from the table to form a 0.5 mm Pb protective wing. All have self-adjusting friction joints ensuring that the shield remains in the desired position.

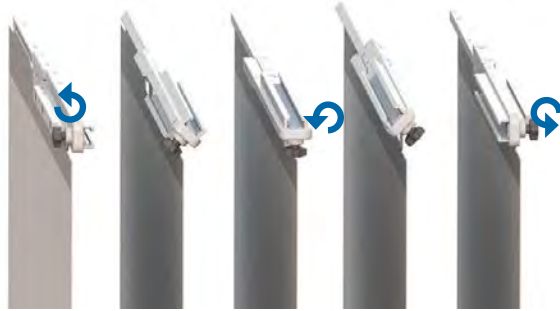

KNX-312/E-022

- Kenex table shields can be moved from one side of the table to the other in an instant by simply rotating the upper part 180° horizontally. The pivotal arm always faces the head end.
- To position a table shield, slide the attachment bracket onto the tableside accessory rail.
- All shields have an automatic wear adjustment facility ensuring accurate joint friction preventing unwanted curtain movement even when the table is tilted in any direction.
- The suspended curtain forms a single 'safe zone of occupancy' for the Radiologist (or Cardiologist). This can be extended by the use of top shields.
- The curtain forms around an under table x-ray tube without impeding movement.
- When used in conjunction with Kenex ceiling mounted systems, both upper & lower body protection meet to provide an effective & easy to use barrier to scatter radiation.



Side profile showing attachment

Curtain construction

The flexible curtain suspended from each shield provides 0.5 mm Pb protection. It consists of a flexible inner layer with a durable outer covering bonded to it. This results in an extremely strong, supple, easy to clean curtain which cannot delaminate. All shields are supplied with a curtain which easily forms around a C-Arm without impeding C-Arm movement.

Alternative construction

Shields with curtains made using three overlapping panels are available to special order – Add 'P' to the end of the required stock code. Shields with overlapping panels are a no cost option.



Automatic wear adjustment

Top shields

Kenex top shields are manufactured using the same 0.5 mm Pb protective material as the suspended curtains of the main shield. They include a flexible plastic material that enables them to stand 25 cm above the tableside rail, and provide additional higher and wider protection to the user. Their unique shape (wider at the top) ensures that no gaps develop as the adjacent tops are pushed towards the patient during procedures.



Top shields

78 cm wide with a single friction pivot

- 78 cm shields can be quickly adjusted to fit either a 25 mm or 28.6 mm high tableside rail (max. 11 mm depth).
- Can be fitted to either side of the table with the pivotal arm always positioned towards the head end.
- 70 cm high curtain.

One piece table shield without a top shield	KNX-312/E-005
Alternative model with overlapping curtain panels	KNX-312/E-005/P
One piece table shield with a 57 cm wide lift-off top shield	KNX-312/E-006
Alternative model with overlapping curtain panels	KNX-312/E-006/P



KNX-312/E-005

One piece curtain



KNX-312/E-005



KNX-312/E-006 (with lift-off top)

Overlapping curtains



KNX-312/E-005/P



KNX-312/E-006/P (with lift-off top)

89 cm wide with a double friction pivot

- Shield fits onto a 25 x 10 mm tableside rail.
- 70 cm high curtain.
- Wall rack is included.

Table shield with overlapping curtain panels and a 52 cm wide fold-down top shield	KNX-311/DS-020
---	----------------



KNX-311/DS-020

92 cm wide with a double friction joint

- 92 cm shields can be quickly adjusted to fit either a 25 mm or 28.6 mm high tableside rail (max. 11 mm depth).
- Can be fitted to either side of the table with the pivotal arm always positioned towards the head end.
- 70 cm high curtain.

One piece table shield without a top shield	KNX-312/E-010
Alternative model with overlapping curtain panels	KNX-312/E-010/P
One piece table shield with a 57 cm wide lift-off top shield	KNX-312/E-011
Alternative model with overlapping curtain panels	KNX-312/E-011/P
One piece table shield with a 57 cm wide fold-down top shield	KNX-312/E-012
Alternative model with overlapping curtain panels	KNX-312/E-012/P



One piece curtain



KNX-312/E-010



KNX-312/E-011 (with lift-off top)



KNX-312/E-012 (with fold-down top)

Overlapping curtains



KNX-312/E-010/P



KNX-312/E-011/P (with lift-off top)



KNX-312/E-012/P (with fold-down top)

100 cm wide with a single friction pivot

- 100 cm shields can be quickly adjusted to fit either a 25 mm or 28.6 mm high tableside rail (max. 11 mm depth).
- They have a 35 cm long integrated accessory rail which keeps equipment controls close to hand.
- Can be fitted to either side of the table with the pivotal arm always positioned towards the head end.
- 70 cm high curtain.



One piece table shield without a top shield	KNX-312/E-010
Alternative model with overlapping curtain panels	KNX-312/E-010/P
One piece table shield with a 57 cm wide lift-off top shield	KNX-312/E-011
Alternative model with overlapping curtain panels	KNX-312/E-011/P
One piece table shield with a 57 cm wide fold-down top shield	KNX-312/E-012
Alternative model with overlapping curtain panels	KNX-312/E-012/P

One piece curtain



KNX-312/E-015



KNX-312/E-016 (with lift-off top)

Overlapping curtains



KNX-312/E-015/P



KNX-312/E-016/P (with lift-off top)

114 cm wide with a double friction joint

- 114 cm shields can be quickly adjusted to fit either a 25 mm or 28.6 mm high tableside rail (max. 11 mm depth).
- They have a 35 cm long integrated accessory rail which keeps equipment controls close to hand.
- Can be fitted to either side of the table with the pivotal arm always positioned towards the head end.
- 70 cm high curtain.

Description	With accessory rails	
	350 x 10 x 25 mm & 350 x 9.5 x 28.6 mm	With accessory rail 350 x 7.7 x 25 mm
One piece table shield without a top shield	KNX-312/E-020	KNX-312/E-020/8
Alternative model with overlapping curtain panels	KNX-312/E-020/P	KNX-312/E-020/8P
One piece table shield with a 57 cm wide lift-off top shield	KNX-312/E-021	KNX-312/E-021/8
Alternative model with overlapping curtain panels	KNX-312/E-021/P	KNX-312/E-021/8P
One piece table shield with a 57 cm wide fold-down top shield	KNX-312/E-022	KNX-312/E-022/8
Alternative model with overlapping curtain panels	KNX-312/E-022/P	KNX-312/E-022/8P
One piece table shield with a 57 cm & 2 x 27 cm wide lift-off top shields	KNX-312/E-020/3	KNX-312/E-020/3/8
Alternative model with overlapping curtain panels	KNX-312/E-020/3/P	KNX-312/E-020/3/8P



KNX-312/E-022



Accessory Rail

One piece curtain



KNX-312/E-020



KNX-312/E-021
(with lift-off top)



KNX-312/E-022
(with fold-down top)



KNX-312/E-020/3
(with 3 x lift-off tops)

Overlapping curtains



KNX-312/E-020/P



KNX-312/E-021/P
(with lift-off top)



KNX-312/E-022/P
(with fold-down top)



KNX-312/E-020/3/P
(with 3 x lift-off tops)

Collision Resilient

Collision resilient table mounted lower body shields

Unique patented mechanism enables the pivotal arm to move up when in collision with C-arm equipment.

- All models have a double-jointed pivotal arm supporting a protective 0.5 mm lead equivalent flexible curtain.
- The pivotal arm and curtain can move up when a C-arm is in contact from below.
- The curtain can move laterally close to the tableside or swivel away to form a protective wing.

92 cm wide collision resilient with a double friction joint

- 92 cm shields can be quickly adjusted to fit either a 25 mm or 28.6 mm tableside rail (max. 11 mm depth).
- Can be fitted to either side of the table, with the pivotal arm always positioned towards the head end.

Collision resilient shield with 57 cm wide lift-off top (70 cm high curtain)	KNX-312/E-013
Alternative model with overlapping curtain panels	KNX-312/E-013/P
Collision resilient shield (75 cm high curtain)	KNX-312/DS-008
Including set of three top shields (1 x fold-down/lift-off & 2 x lift-off)	KNX-312/DS-008/3



KNX-312/E-013
with top shield removed



KNX-312/E-013
(with lift-off top)



KNX-312/E-013/P
(with lift-off top)



KNX-312/DS-008



KNX-312/DS-008/3
(with 1 x fold-down/lift-off top & 2 x lift-off tops)

114 cm wide collision resilient with a double friction joint

- 114 cm shields can be quickly adjusted to fit either a 25 mm or 28.6 mm high tableside rail (max. 11 mm depth).
- They have a 35 cm long integrated accessory rail which keeps equipment controls close to hand.
- Can be fitted to either side of the table with the pivotal arm always positioned towards the head end.
- 70 cm high curtain.

Description	With accessory rails 350 x 10 x 25 mm & 350 x 9.5 x 28.6 mm	
	With accessory rail 350 x 7.7 x 25 mm	
Collision resilient shield with 57 cm wide lift-off top	KNX-312/E-023	KNX-312/E-023/8
Alternative model with overlapping curtain panels	KNX-312/E-023/P	KNX-312/E-023/8P



KNX-312/E-023
with top shield removed



KNX-312/E-023
(with lift-off top)



KNX-312/E-023/P
(with lift-off top)

137 cm wide collision resilient with a double friction joint

- 137 cm shields can be quickly adjusted to fit either a 25 mm or 28.6 mm high tableside rail (max. 11 mm depth).
- They have a 57 cm long integrated accessory rail to keep equipment controls close to hand.
- Can be fitted to either side of the table with the pivotal arm always positioned towards the head end.
- These shields can also overhang the tableside rail to be positioned nearer the head end.
- 75 cm high curtain.



Description	With accessory rails 350 x 10 x 25 mm & 350 x 9.5 x 28.6 mm	
Collision resilient table shield		KNX-312/DS-039/6
Including set of three top shields (3 x lift-off)		KNX-312/DS-0412/6
Including set of three top shields (1 x fold-down/lift-off & 2 x lift-off)		KNX-312/DS-039/6/3



KNX-312/DS-039/6



KNX-312/DS-0412/6
(with 3x lift-off tops)



KNX-312/DS-039/6/3
(with 1 x fold-down/lift-off top & 2 x lift-off tops)

137 cm wide collision resilient with a double friction joint and deep attachment bracket

- Deep attachment bracket allowing transverse table movement
- 137 cm shields can be quickly adjusted to fit either a 25 mm or 28.6 mm high tableside rail (max. 11 mm depth).
- They have a 65 cm long integrated accessory rail to keep equipment controls close to hand.
- Can be fitted to either side of the table with the pivotal arm always positioned towards the head end.
- These shields can also overhang the tableside rail to be positioned nearer the head end.
- 75 cm high curtain.



With accessory rails
650 x 10 x 25 mm &
650 x 9.5 x 28.6 mm

Description

Collision resilient table shield with deep attachment bracket	KNX-312/DS-060
Including set of three top shields (1 x fold-down/lift-off & 2 x lift-off)	KNX-312/DS-060/1/3



KNX-312/DS-060



KNX-312/DS-060/1/3
(with 1 x fold-down/lift-off top & 2 x lift-off tops)



Accessory rail clearance on a table
with lateral movement

162 cm wide collision resilient with 2 x double friction joint

- 162 cm shields can be quickly adjusted to fit either a 25 mm or 28.6 mm high tableside rail (max. 11 mm depth).
- They have a 57 cm long integrated accessory rail to keep equipment controls close to hand.
- Can be fitted to either side of the table with the pivotal arm always positioned towards the head end.
- These shields can also overhang the tableside rail to be positioned nearer the head end.
- 75 cm high curtain.



With accessory rails
570 x 10 x 25 mm &
570 x 9.5 x 28.6 mm

Description

Collision resilient table shield	KNX-312/DS-039/10
Including set of three top shields (1 x fold-down/lift-off & 3 x lift-off)	KNX-312/DS-039/10/4



KNX-312/DS-039/10



KNX-312/DS-039/10/4
(with 1 x fold-down/lift-off top & 3 x lift-off tops)

Top Shield Options and Replacements

Top shields quickly and easily attach to different table mounted Kenex lower body radiation shields, providing additional protection to the user (see separate datasheet for compatibility). Some table shields come with one or more top shields but these are available as optional extras.

- Removeable, 0.5mm Pb X-ray protective top shields
- Slot into docking holes and can be mounted and removed in an instant.
- Standard height tops stand 25 cm above the centre line of the table side rail, reduced height tops are 10 cm shorter and stand 15 cm above.
- Can be stored on a wall rack when not required.

Additional upper protection

57 cm wide tops used together with 27 cm wide tops provide the following total upper protection:-

Description	Upper Protection Width
57 cm wide top only	57 cm wide
57 cm wide top with 1 x 27 cm wide top	74 cm wide
57 cm wide top with 2 x 27 cm wide top	92 cm wide

Note: 78 cm table shields can only accomodate 1 x 57 cm and 1 x 27 cm top shield.



KNX-312/E-021/P



Slot into docking holes

312 – Top shield sets

- Top shields are flexible and stand 25 cm above the table side rail. Reduced height top shields stand 15 cm above.
- 27 and 57 cm wide shield combinations give up to 92 cm wide upper protection.

Description	Product Code
Standard height, set of three lift-off top shields. Compatible with 312/E-020, 312/E-021, 312/E-022, 312/E-023, 312/DS-039/6& variants.	KNX-312/E/025
Reduced height, set of three lift-off top shields. Compatible with 312/E-020, 312/E-021, 312/E-022, 312/E-023, 312/DS-039/6 & variants.	KNX-312/E/025



KNX-312/E/025



KNX-312/E/027

312/DS – 57 cm wide top shield options and replacements

- Top shields are flexible and stand 25 cm above the tableside rail. Reduced height top shields stand 15 cm above.
- A data sheet showing compatibility is available on our website or by request.

Description	Product Code
57 cm wide, standard height, lift-off top	KNX-312/E/025
57 cm wide, standard height, fold-down top, not removable	KNX-312/E/025
57 cm wide, standard height, fold-down / lift-off top	KNX-312/DS/3.115
57 cm wide, reduced height, lift-off top	KNX-312/DS/3.128
57 cm wide, reduced height, fold-down top, not removable	KNX-312/DS/3.139
57 cm wide, reduced height, fold-down / lift-off top	KNX-312/DS/3.167



KNX-312/DS/3.32



KNX-312/DS/3.33



KNX-312/DS/3.115



KNX-312/DS/3.128



KNX-312/DS/3.139



KNX-312/DS/3.167

312/DS – 27 cm wide top shield options and replacements

- Top shields are flexible and stand 25 cm above the tableside rail. Reduced height top shields stand 15 cm above.
- A data sheet showing compatibility is available on our website or by request.

Description	Product Code
27 cm wide, standard height, lift-off top	KNX-312/DS/3.30
27 cm wide, standard height, lift-off top (cropped)	KNX-312/DS/3.41
27 cm wide, standard height, lift-off top (cropped)	KNX-312/DS/3.122
27 cm wide, reduced height, lift-off top	KNX-312/DS/3.108
27 cm wide, reduced height, lift-off top (cropped)	KNX-312/DS/3.110
27 cm wide, reduced height, lift-off top (cropped)	KNX-312/DS/3.130



KNX-312/DS/3.30



KNX-312/DS/3.41



KNX-312/DS/3.122



KNX-312/DS/3.108



KNX-312/DS/3.110



KNX-312/DS/3.130

Top Shields

These lower body shields substantially reduce exposure to scatter radiation emanating from the table or patient's body. They comprise of a lightweight and durable structure supporting a flexible 0.5 mm lead equivalent curtain or multiple curtains.

- The shield slides onto a carbon fibre table top and maintains its position even when the table is tilted.
- The pivotal side wings can be formed around the user, individually extended forward along the table side, or folded neatly away according to preference. The pivotal arms can be quickly repositioned to allow full C-arm movement.
- Each shield is manufactured to suit a specific table and can be provided with an optional wall storage rack if not already included. This allows the shield arms to be folded inwards to reduce wall space to a minimum.

KNX-313/A2

56 cm wide central section and two 32 cm wide pivotal side wings, supporting an 80 cm long flexible 0.5 mm Pb equivalent curtain. Total width: 120 cm (dependent upon make of table).

Description	Product Code
Head end table shield	KNX-313/A2
Optional wall rack	On request
Head end table shield & wall rack for use with a 525 mm wide Artis table or 520 mm wide TruSystem 7500 for Artis zee systems	KNX-313/A2-001
Head end table shield & wall rack for use with a 550 mm wide Artis zee multipurpose (MP) table	KNX-313/A2-008



KNX-313/A2

KNX-313/A3

57 cm wide central section and two 31 cm wide pivotal side wings, supporting an 80 cm long flexible 0.5 mm Pb equivalent curtain. The flexible 57 cm wide x 27 cm high top shield folds down when required.

Description	Product Code
Head end table shield and flexible 57 cm wide x 27 cm high fold down top shield for use with a 500 mm wide Allura AD7 table	KNX-313/A3-001
Optional wall rack	KNX-313/A3-001/W
Head end table shield and flexible 57 cm wide x 27 cm high fold down top shield for use with a 500 mm wide Allura AD7 table - wall rack included	KNX-313/A3-002



KNX-313/A3-001
Top shield shown folded down

KNX-311/TC – Upper foot end table shield

- This shield protects against scatter radiation and also helps protect against possible blood splashes during some interventional procedures.
- Designed for use across the table towards the foot end.
- Fits onto both 25 mm high table side accessory rails (7.7 - 10 mm thick).
- Lead acrylic window 60 cm high x 80 cm wide (dependent on table width), with lower flexible curtain.
- Overall height: 90 cm.
- Lead equivalent protection throughout: 0.5 mm.

Description	Product Code
Table end upper shield	KNX-311/TC/004



KNX-311/TC/004

Table Mounted Shield Storage

Wall racks for table mounted lower body shields

- These racks provide a convenient storage location when shields are removed from the table side.

Description	Product Code
Wall rack for a lower body shield (type 312)	KNX-312/W-LB
Wall rack for 1 x 57 cm wide top shield and 2 x 27 cm wide top shields	KNX-312/W-TOP
Wall rack set, includes both wall racks listed above (1 x 312/W-LB & 1 x 312/W-TOP)	KNX-312/W-LBT



KNX-312/W-TOP



KNX-312/W-LB



KNX-312/W-LBT
(shielding not included)

Mobile racks for table mounted lower body shields

Effective mobile storage combinations for lower body table shields (type 312), removable Kenex top shield sets (1 x 57 cm and 2 x 27 cm wide) and optional head end shields (type 313).

Description	Product Code
Mobile rack for 1 x table shield, 1 x set of top shields and 1 x head end shield	KNX-1342/A2/E-001
Mobile rack for 2 x table shields and 2 x sets of top shields	KNX-1342/A2/F



KNX-1342/A2/E-001
Shields not included



KNX-1342/A2/F
Shields not included

Suspended Shielding

Femoral and Radial Access Protective Shield

Modern X-ray protection for today's applications, particularly for the increase of radial access and longer interventional procedures:

Recent studies have shown that a significant amount of radiation is emitted not only through the gap between the patient and shield, but also from the patient itself.

Even if the shield sits directly on top of the patient, radiation travels under the shield through the patient and is then released. To combat this, flexible strips were added to the bottom of the shield. The special design and the flexibility of the curtain allows it to perfectly adapt to the patient's body without producing gaps between the strips, reducing the scatter radiation emitting from the patient's body in the direction of the user.

Additionally, the second patient cut-out in combination with the flexible strips ensures optimal radiation protection during femoral, as well as radial access procedures.

MVG-OT54001 / MVG-OT94001 – Radiation protective shield with two patient cut-outs and X-ray protective strips:

- Lead Acrylic Shield Size: 78 x 90 cm (W x H)
- Lead Equivalent: 0.50 mm Pb
- Centrally guided by connecting element
- Weight includes X-ray protective strips: 15.0 kg
- Accessories: Specially designed sterile covers MVG-STE-OT4 to meet the strict hygienic regulations of hospitals

X-Ray Protective Strips

- Flexible X-Ray Protection
- Lead equivalent 0.5 mm Pb



Description

Laterally Guided Shield W/ Cutout

Product Code

MVG-OT54001

Challenge

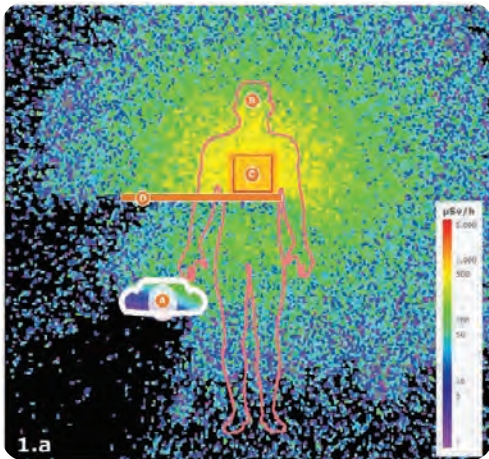

Solution

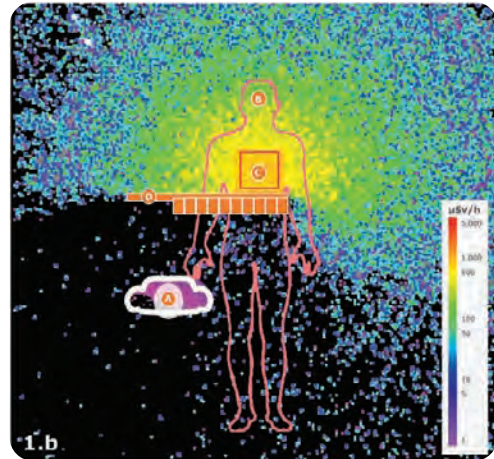

In order to test the efficiency of a shielding curtain, the scattered radiation distribution was simulated using the Monte Carlo method for the new radiation protective shield both with and without a curtain. See fig. 1.a and 1.b

The protection for the examiner's upper body has increased 85% compared with the shield without a curtain.



Transparent Acrylic Shield (With Patient Contour Cutout)
Centrally guided via connecting element. Features a patient contour cutout for more flexible usage and positioning over the patient.

- Shield size: 61 x 76 cm (W x H)
- Lead equivalent: 0.50 mm Pb

Description	Product Code
Lead Acrylic Shield W/ Cutout	MVG-OT50001



Transparent Acrylic Shield MVG-OT50002
Centrally guided by connecting element without protective strips.

- Shield size: 50 x 39 cm (W x H)
- Lead equivalent: 0.50 mm Pb

Description	Product Code
Lead Acrylic Shield	MVG-OT50002



Transparent Acrylic Shield MVG-OT50011
Centrally guided by connecting element with flexible radiation protective strips in hygienic PVC cover.

- Shield size: 50 x 39 cm (W x H)
- Strip size: 50 x 35 cm (W x H)
- Lead equivalent: 0.50 mm Pb

Description	Product Code
Lead Acrylic Shield	MVG-OT50011



Transparent Acrylic Shield MVG-OT80001,-02,-03
Transparent acrylic shield, 0.50 mm Pb, laterally guided with 350mm flexible lead rubber panels in hygienic PVC cover. Includes a preset Portegra2 suspension arm OT50U040, 750/910 mm, non-electrical.

Description	Product Code
Transparent acrylic shield MVG-OT40B01, dimensions: 400 x 300 mm	MVG-OT80001
Transparent acrylic shield MVG-OT40B02, dimensions: 500 x 380 mm	MVG-OT80002
Transparent acrylic shield MVG-OT40B02, dimensions: 760 x 350 mm	MVG-OT80003



Transparent Acrylic Shield MVG-OT50003
Laterally guided with cut-out for positioning over the patient.

- Shield size: 76 x 60 cm (W x H)
- Lead equivalent: 0.50 mm Pb

Description	Product Code
Lead Acrylic Shield	MVG-OT50003

Urological Intervention Procedure Head Protection

Until now, the necessity of appropriate radiation protective measures for urological interventions in the lithotomy position has not been of a peculiar interest. However a new study has shown that the scattered radiation coming out of the patient's body leads to a high exposure to the doctor during urology interventions. Common radiation protective shields are seldomly used due to the special positioning of the patient and the confined space it creates.

The newly developed design is ideally suited for the urological workflow. The shield offers optimal protection against scattered radiation for the operator in a highly restricted workspace during urologic interventions carried out in lithotomy position. The high quality shield made of lead acrylic allows for an excellent transmittance and hence an unimpeded view.

- Shield size: 78 x 90 cm (W x H)
- Lead equivalent: 0.50 mm Pb

Description	Product Code
Urological Interventional Procedure Shield	MVG-OT81001
Urological Interventional Procedure Shield	MVG-OT91001



Suspended Shielding

Kenex's comprehensive range of x-ray shielding equipment significantly reduces secondary radiation exposure to staff during all applications.

The installation of ceiling suspended lead acrylic or lead glass shields minimise dose to the head, lens of the eye and upper body, and importantly provide instant access to the patient in an emergency. Tableside mounted shields protect the lower body and extremities and when combined, provide a safe and effective zone of occupancy. Mobile over-table and alongside table versions are also available.



Upper body radiation shields - 354

- Material: transparent lead acrylic, lead equivalent 0.5 mm.
- Portrait orientation, but central ball and socket joint provides rotational and tilting movement.

With a patient contour corner cut-out

Dimensions:

- 76 cm high x 61 cm wide

354 - 76x61 Cut-out Shield w/ Stationary	KNX-354/P/76-001
354 - 76x61 Cut-out Shield w/ Mobile	KNX-354/P/76-0031
354 - 76x61 Flexible 0.5 mm lead panels	KNX-354/P/LR

Without a corner cut-out

Dimensions:

- 76 cm high x 61 cm wide
- 40 cm high x 50 cm wide

354 - 76x61 Shield w/ Stationary	KNX-354/76-001
354 - 76x61 Shield w/ Mobile	KNX-354/76-0031
354 - 76x61 Flexible 0.5 mm lead panels	KNX-354/LR/61
354 - 40x50 Shield w/ Stationary	KNX-354/45-001
354 - 40x50 Shield w/ Mobile	KNX-354/45-0031
354 - 40x50 Flexible 0.5 mm lead panels	KNX-354/LR/50

Stationary installation

Protective shields for static installation on the ceiling are supplied with a suspension arm and an 80 cm long ceiling column as standard, with other lengths of 40 cm, 60 cm and 100 cm available. The suspension arm comprises an extension and spring arm combination with a combined reach of 186 cm. The ceiling column has a spare pivot, equipped with an internal electrical connector, for mounting a second suspension arm and another device; such as the lamp illustrated.

Movable installation

Shields for flexible positioning across the ceiling are additionally supplied with a 250 cm long heavy duty aluminium ceiling track with a movable carriage. Track mounted devices can be moved and positioned in the working area or parked up to 5.9 meters away. An optional second carriage provides independent movement of further attached devices, such as injectors, monitors, lamps or extra shields.



Upper body radiation shields - 351

- Material: transparent lead acrylic, lead equivalent 0.5 mm.
- Landscape orientation only.

With a patient contour corner cut-out

Dimensions:

- 60 cm high x 80 cm wide

351 - 60x80 Cut-out Shield w/ Stationary	KNX-351/P/68-001
351 - 60x80 Cut-out Shield w/ Mobile	KNX-351/P/68-0031
351 - 60x80 Flexible 0.5 mm lead panels	KNX-351/P/LR

Without a corner cut-out

Dimensions:

- 60 cm high x 80 cm wide
- 40 cm high x 50 cm wide

351 - 60x80 Shield w/ Stationary	KNX-351/68-001
351 - 60x80 Shield w/ Mobile	KNX-351/68-0031
351 - 60x80 Flexible 0.5 mm lead panels	KNX-351/LR/80
351 - 40x50 Shield w/ Stationary	KNX-351/45-001
351 - 40x50 Shield w/ Mobile	KNX-351/45-0031
351 - 40x50 Flexible 0.5 mm lead panels	KNX-351/LR/50



Eyes and thyroid radiation shields - 350

- Material: Lead glass, with minimum 2.2 mm lead equivalent.
- Fitted flexible lower curtain: lead equivalent 0.5 mm.

Dimensions:

- 40 cm high x 50 cm wide
- 30 cm high x 40 cm wide

350 - 40x50 Shield w/ Stationary	KNX-350/45-001
350 - 40x50 Shield w/ Mobile	KNX-350/45-0031
350 - 30x40 Shield w/ Stationary	KNX-350/45-001
350 - 30x40 Shield w/ Mobile	KNX-350/45-0031

Overhead flexible lead shield - 308

Overlapping panels with a fold-up centre section retained by a press stud.

- Material: flexible 0.5 mm Pb equivalent lead vinyl.
- Size: 50 cm high x 100 cm wide.
- Ceiling model has an 80 cm long ceiling column. 60 & 100 cm lengths are optional.

Other sizes available on request.

Shield w/ arm, ceiling column	308/50100-001
Shield w/ arm, wall mounting bracket	308/50100-005

Ceiling Mounted Shield and Lamp - 354/351/350

All lamps have daylight characteristics, light field focussing, dimming with on/off switch, sterilisable handle, power supply unit and a 950/910 mm suspension arm.

354 - 76x61 Shield, w/ Stationary and lamp: LED 130F	KNX-354/P76/LED130F-001
354 - 76x61 Shield, w/ Stationary and lamp: LED 150F	KNX-354/P76/LED150F-001
354 - 76x61 Shield, w/ Stationary and lamp: LED 300DF SC	KNX-354/P76/LED3DF-001
354 - 76x61 Shield, w/ Mobile and lamp: LED 130F	KNX-354/P76/LED130F-0031
354 - 76x61 Shield, w/ Mobile and lamp: LED 150F	KNX-354/P76/LED150F-0031
354 - 76x61 Shield, w/ Mobile and lamp: LED 300DF SC	KNX-354/P76/LED3DF-0031
351 - 60x80 Shield, w/ Stationary and lamp: LED 130F	KNX-351/P68/LED130F-001
351 - 60x80 Shield, w/ Stationary and lamp: LED 150F	KNX-351/P68/LED150F-001
351 - 60x80 Shield, w/ Stationary and lamp: LED 300DF SC	KNX-351/P68/LED3DF-001
351 - 60x80 Shield, w/ Mobile and lamp: LED 130F	KNX-351/P68/LED130F-0031
351 - 60x80 Shield, w/ Mobile and lamp: LED 150F	KNX-351/P68/LED150F-0031
351 - 60x80 Shield, w/ Mobile and lamp: LED 300DF SC	KNX-351/P68/LED3DF-0031
350 - 40x50 Shield, w/ Stationary and lamp: LED 130F	KNX-350/45/LED130F-001
350 - 40x50 Shield, w/ Stationary and lamp: LED 150F	KNX-350/45/LED150F-001
350 - 40x50 Shield, w/ Stationary and lamp: LED 300DF SC	KNX-350/45/LED3DF-001
350 - 40x50 Shield, w/ Mobile and lamp: LED 130F	KNX-350/45/LED130F-0031
350 - 40x50 Shield, w/ Mobile and lamp: LED 150F	KNX-350/45/LED150F-0031
350 - 40x50 Shield, w/ Mobile and lamp: LED 300DF SC	KNX-350/45/LED3DF-0031





Suspension Systems

Imaging Solutions offers a range of Ceiling Suspension Systems designed to enhance the efficiency and safety of medical imaging procedures in operating theatres. Our product range includes ceiling-mounted systems that allow for easy and flexible positioning of medical equipment such as surgical lights, monitors, and cameras.

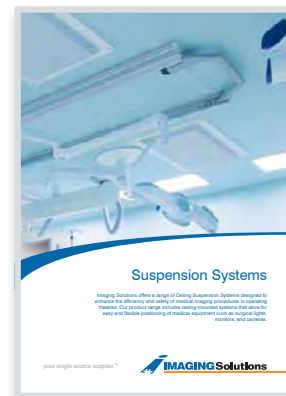

See our Suspension Systems catalogue for our full range.

Operating Lamps

Our modern ergonomic lamps create ideal examination and operating conditions

Such as daylight characteristics, cool light technology with almost non-existent heat dispersion, faceted multi-lenses for even illumination, high contrast colour rendering for recognition of colour tones and controls to alter the light field size and intensity. LED MC models enable the colour temperature values to be altered to create a range of settings according to preference or application. For example 4500 or 4750 Kelvin for cold-white or warm-white light.

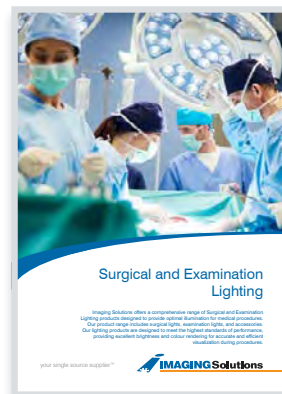

See our Surgical and Examination Lighting catalogue for our full range of Kenex Operating Lamps



RADview Lead Lined Window Frames

Imaging Solutions offers world-class Australian designed aluminium framed X-ray protective examination window frames.

Our lead lined window frames are suitable for customisation to your facility needs, from varied lead thicknesses to suit your procedural requirements, and powder coating to your preferred colour of choice.

These radiation protective window frames can be fitted to the specification of the required room up to 2400 mm long and 1200 mm high, with an adjustable wall thickness from 90 mm to 150 mm. Lead lined window frames provide full protection to the total structural opening within the X-ray room, with each frame manufactured and pre-assembled in our warehouse to save time and effort once on-site.

Contact us for more information or to enquire about our wide range of lead thicknesses, standard and non-standard sizes available for special orders and specific applications.



Corning Radiation Protective Glass

Radiation Shielding Glass Applications

Why use radiation shielding glass?

Wherever X-ray and gamma ray technologies are used, radiation shielding glass can protect people from ionizing radiation (interventional cardiology, CT scans, radiation therapy, etc.).

Medical, technical, and industrial applications:

- Fixed windows in hospitals or smaller practices
- Suspended or mobile panels in hospitals or smaller practices
- Research laboratories
- Industrial scanners and non-destructive testing

Radiation Shielding Glass Product Range

Corning® Med-X® Glass and Corning® Med-Gamma® Glass

Corning is one of the worldwide leaders in radiation shielding glass, with years of experience providing high-quality glass with a comprehensive range of thickness and sizes.

Corning® Med-X® Glass for X-Ray shielding:

- Observation windows & panoramic glazing door glazing
- panel (fixed and mobile)
- Glove boxes for X-Ray rooms
- CT scanning facilities

Corning® Med-X® Glass for Gamma-Ray shielding:

- Windows for nuclear medicine applications including hot cell, cyclotron, and PET scanning

Corning® Med-X® Glass is supplied as polished plates in the largest available sizes on the market (up to 2,800 x 1,400 mm) and as finished, cut-to-size plates. Customized shapes and finishing are available upon request for the widest range of possibilities.

CORNING

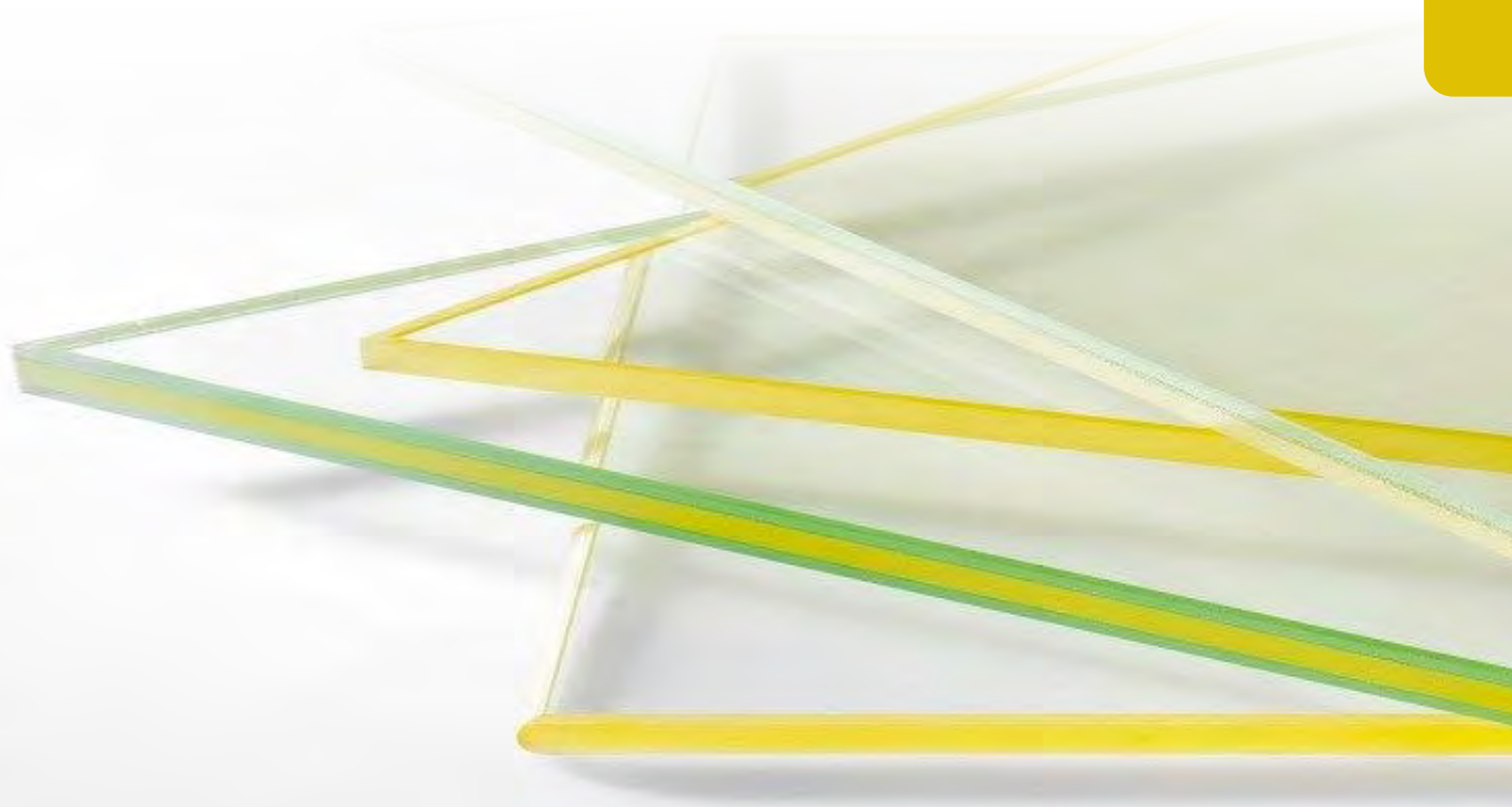
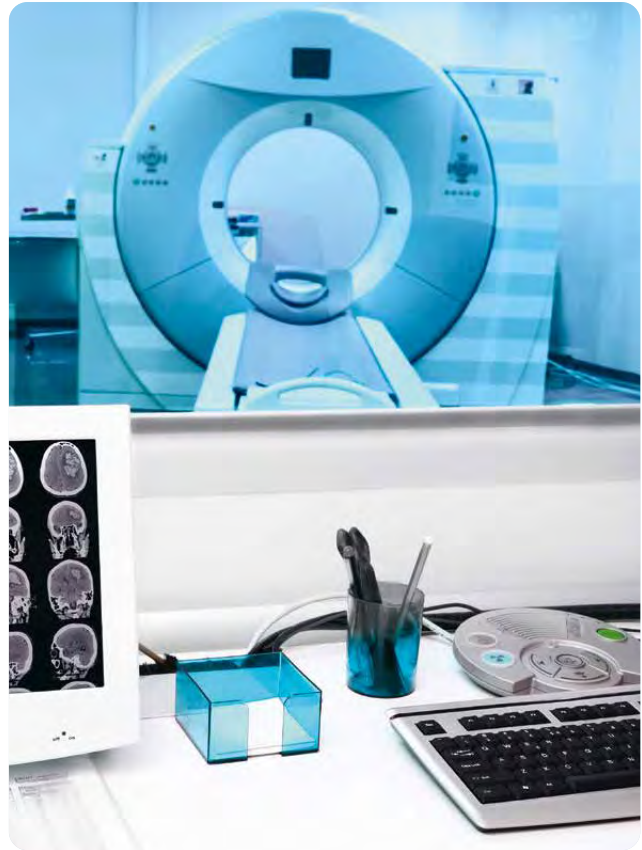

Med-X[®] Glass for Typical Shielding Applications

Radiation Shielding Glass for medical, technical and research applications.

Corning is a world leader in Radiation Shielding Glass offering some of the largest glass sizes available.

Corning[®] Med-X[®] Glass is supplied as polished plates with dimensions up to 2800 x 1400 mm and is available worldwide with quick delivery times.

Key Benefits

- Shields against X-Rays from equipment operating in the 80 to 300 kV range.
- High Barium and lead content providing optimum protection with excellent visual clarity.
- Supplied as polished plates cut to customer requirements up to 2800 x 1400 mm, allowing architects to design viewing windows with a wider field of vision.
- Also available in sizes cut specifically to customer requirements (with cut edges ground or polished and finished with safety chamfers).
- Extensive stocks held in all plate sizes and thicknesses at distribution points worldwide, for immediate cutting and despatch.

Applications

- Viewing windows for X-Ray, Angiography Rooms, CT Scans.
- Screens for medical diagnostics.
- Protection windows in laboratories.
- Airport security X-ray screens.
- Lenses for safety goggles.

Physical Properties

Optical Properties

- Refractive Index nd: 1.76
- Transmission % @ 550nm through 5mm path: ≥85.0

Mechanical Properties

- Torsion Modulus (Gpa): 24.8

Chemical Properties

- Heavy oxide content: <70%



Glass Thickness		Minimum lead equivalence (mm) for stated X-Ray tube voltage							Max. Plate Mass	
mm	inches	80kV	100kV	110kV	150kV	200kV	250kV	300kV	kg/m2	lbs/ft2
4.0-5.5	0.157 - 0.217	1.4	1.4	1.3	1.2	1	1	1	26.4	5.4
5.0-6.5	0.197 - 0.256	1.7	1.7	1.7	1.5	1.3	1.3	1.3	31.2	6.4
5.7-7.0	0.224 - 0.276	1.9	1.9	1.9	1.7	1.5	1.5	1.5	33.6	6.9
7.0-8.5	0.276 - 0.335	2.3	2.3	2.3	2.1	1.8	1.8	1.8	40.8	8.4
8.5-10.0	0.335 - 0.394	2.7	2.8	2.9	2.6	2.1	2.1	2.2	48	9.8
10.0-12.0	0.394 - 0.472	3.2	3.2	3.3	2.9	2.5	2.6	2.6	57.6	11.8
11.0-13.0	0.433 - 0.512	3.6	3.5	3.6	3.2	2.8	2.8	2.9	62.4	12.8
12.0-14.0	0.472 - 0.551	4	3.8	4	3.5	3	3.1	3.2	67.2	13.8
14.0-16.0	0.551 - 0.630	4.7	4.5	4.6	4.1	3.5	3.6	3.7	76.8	15.7
16.0-18.0	0.630 - 0.709	5.3	5.1	5.3	4.7	4	4.1	4.3	86.4	17.7
18.0-20.0	0.709 - 0.787	6	5.7	5.9	5.2	4.4	4.6	4.8	96	19.7

Med-X[®] Glass for Gamma Applications

Radiation Shielding Glass for medical, technical and research applications.

Corning is a world leader in Radiation Shielding Glass offering a comprehensive range of

products including Corning[®] Med-Gamma[®] Glass. Corning[®] Med-Gamma[®] Glass is supplied as polished plates with dimensions up to 2800 x 1400 mm, and has been designed to provide high quality, transparent and protective shielding from gamma-based PET radiation under various keV levels.



Key Benefits

- Protective shielding glass against gamma-based PET radiation as specified by IEC 61331:2014 (Standard Gamma Radiation).
- Extensive physical testing carried out on Corning[®] Med-Gamma[®] Glass allowing designers to specify glass with maximum confidence.
- High quality and neutral appearance providing excellent visual clarity.
- Corning[®] Med-Gamma[®] Glass is supplied as :
 - » Polished plate up to 2800 x 1400mm
 - » Laminated plate using PVB Interlayer
 - » Cut plate supplied to customer specific sizes (with edges ground or polished and finished with safety chamfers).
- Corning[®] Med-Gamma[®] Glass is stocked worldwide through local Corning sales offices and a network of specialist partners.

Applications

- Occupational protection from PET radiation in scanning techniques for diagnostics and treatment.
- Cyclotron maintenance.

Physical Properties

Optical Properties

- Refractive Index nd: 1.76
- Transmission % @ 550nm through 5mm path: ≥85.0

Chemical Properties

- Lead (Pb): 52%
- Barium (Ba): 17%

Mechanical Properties

- Density (g/cm³): 4.8
- Knoop Hardness (kg/mm²): 409
- Young's Modulus (GPa): 62.6
- Torsion Modulus (GPa): 24.8
- Poisson's Ratio: 0.26
- Coefficient of Thermal Expansion (x10⁻⁷ /°C): 78.8

Shielding Characteristics

Glass Thickness		Minimum lead equivalent (mm) for stated keV			Max. Plate Mass	
mm	inches	511 keV	661 keV	1250 keV	kg/m ²	lbs/ft ²
7.0 - 8.5	0.276 - 0.335	2.3	2.5	2.8	40.8	8.4
8.5 - 10.0	0.335 - 0.394	2.8	3.1	3.5	48	9.8
10.0 - 12.0	0.394 - 0.472	3.3	3.6	4.1	57.6	11.8
11.0 - 13.0	0.433 - 0.512	3.7	4	4.5	62.4	12.8
12.0 - 14.0	0.472 - 0.551	4	4.3	4.9	67.2	13.8
14.0 - 16.0	0.551 - 0.63	4.6	5.1	5.8	76.8	15.7
16.0 - 18.0	0.630 - 0.709	5.3	5.8	6.6	86.4	17.7
18.0 - 20.0	0.709 - 0.787	5.9	6.5	7.4	96	19.7
20.0 - 24.0*	0.787 - 0.945	6.7	7.3	8.5	115.2	23.6
22.0 - 26.0*	0.866 - 1.024	7.3	8.1	9.4	124.8	25.6
24.0 - 28.0*	0.945 - 1.102	8.1	8.9	10.3	134.4	27.5
28.0 - 32.0*	1.102 - 1.260	9.3	10.2	11.7	153.6	31.5
32.0 - 36.0*	1.260 - 1.417	10.7	11.7	13.4	172.8	35.4
36.0 - 40.0*	1.417 - 1.575	12	13.2	15.2	192	39.3
45.0 - 53.0*	1.772 - 2.087	15	16.8	19.2	216	44.2

Data provided by the Public Health England (PHE).

Attenuation measured using the narrow beam method, in accordance with IEC 61331:2014.

Med-X[®] LT Glass

Thin, Clear, and Robust - Corning Innovation

With Corning[®] Med-X[®] LT Glass, Corning innovation continues in the field of Radiation Shielding Glass.

Thanks to an innovative laminated design combining different Corning glasses, new Corning[®] Med-X[®] LT Glass enables improved glazing.

The new radiation shielding solution brings improved features:

- Improved safety in case of impact
- Improved clarity, scratch resistance, and ease of cleaning
- Easy handling and framing thanks to a lightweight design

Combination of Unique Technologies

CORNING[®] MED-X[®] GLASS offers reliable radiationshielding performance and clear transparency for safer X-ray operations.

CORNING[®] ADVANCED GLAZING offers a unique combination of thin, lightweight, and tough properties, enabling a new generation of innovative windows.

Product Life Cycle

From transportation to installation into window panels inside architectural healthcare facilities and laboratory around the world, radiation shielding glass must withstand several constraints during its life cycle:

- Handling, packing, unpacking, and storage
- Daily maintenance and cleaning
- Repeated ionizing radiation

Impact Resistance

Building requirements are becoming increasingly strict with regard to safety standards.

Clarity

Visual comfort and a well-lit work environment are essential for specific glazing materials such as radiation shielding glass.

A new construction project? A new device? Material reliability and ease of use is crucial.

Corning developed a new glass solution bringing safety, durability and user-friendliness for all stakeholders along the product life cycle.

Whether you are a distributor looking for the best solution to offer to your customers, a radiation specialist designing and installing the most reliable X-ray room, or an architect working with engineering consultants looking for the best solution available on the market, the new Corning[®] Med-X[®] LT Glass will meet your expectations.

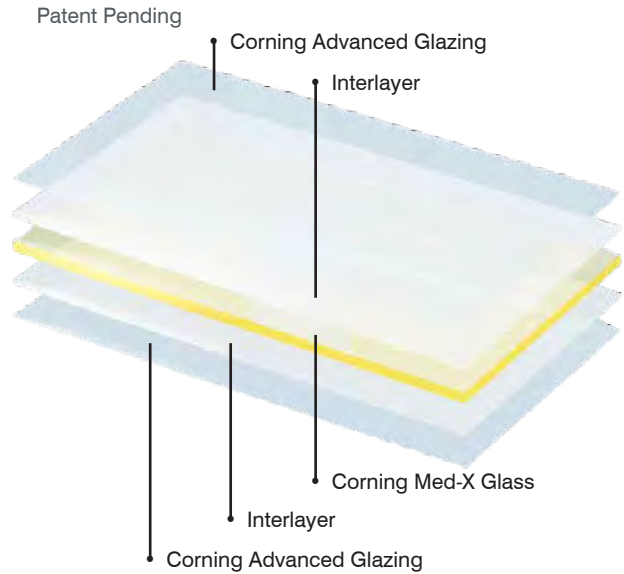

Corning Advanced Glazing = Thin Glass < 1mm



Safety

Protects from ionizing radiation

Corning® Med-X® LT Glass offers excellent radiation protection performance: 1.2 mmPb to 2.6 mmPb lead equivalence at 150 kV tested according to international standard IEC 61 331:2014.

Limits the risk of injury in case of impact Corning® Med-X® LT Glass is a laminated glass.

In case of impact, numerous cracks could appear but fragments are being held together: no projection of glass.

Corning® Med-X® LT Glass is qualified with the most stringent Impact Safety standards for glazing:

- EN 12600 (Europe)
- Cat II CFR Part 16 #1201 (United States)

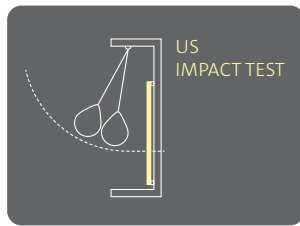
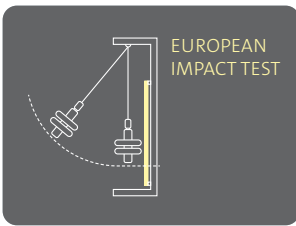

Safety Glazing Impact Test

Safety glass tests reveal how the glass will behave when subjected to an impact of about 50 kg at different drop heights: from a few centimeters to more than 1.20 m (equivalent to an adult hitting the glass unintentionally or a child landing on it accidentally). All tests are performed by accredited independent laboratories.

Durability

Radiation shielding glass requires special care. Corning® Med-X® LT Glass is resistant to scratching and daily cleaning.

Scratch Resistant

Corning® Med-X® LT Glass has better scratch resistance than other products available on the market:

- Up to 4 times better than conventional radiation shielding glass
- 24 times better than lead acrylic panels

It is measured using the ASTM F735-94 abrasion protocol (BAYER test – 3,600 cycles – Corundum sand – Haze measurements).

Easy to clean

Corning® Med-X® LT Glass is easy to clean with common detergents.

Light Transmission Comparison*

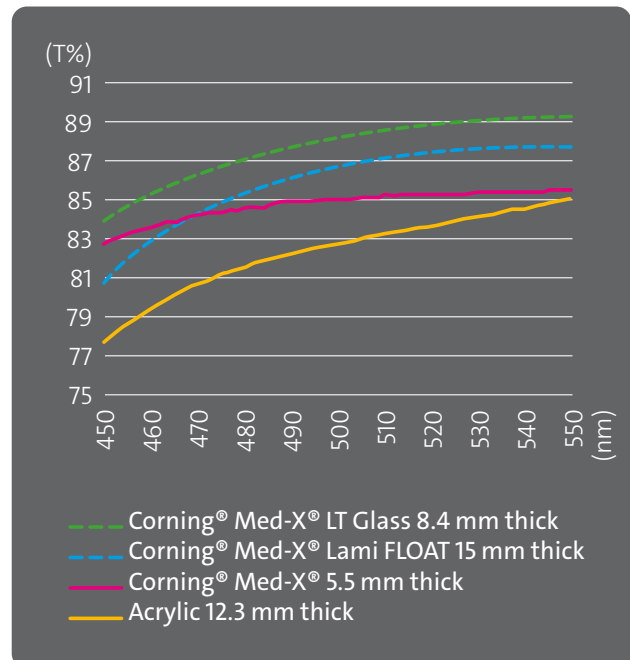

* Light transmission % for different materials Shielding @150 kV of 1.2 mm Pb for glass vs 0.5 mm Pb for acrylic

User-Friendliness

Improved clarity for users

Corning® Med-X® LT Glass guarantees the properties and reliability of a premium radiation shielding glass while offering improved clarity and transparency. Visual clarity is improved as the new solution brings up to 5 extra points of light transmission.

Added value for installers and integrators

Corning® Med-X® LT Glass provides the added value of a laminated sheet without the constraints of extra weight and thickness. Compared to current solutions on the market, Corning® Med-X® LT Glass is up to 10 kg/m² lighter.



Kuraray Kyowa Radiation Protective Acrylic

KYOWAGLAS-XA is a transparent lead-containing plastic sheet manufactured by chemically introducing lead into the resin by co-polymerization. This is a radiation shielding material developed by Kuraray Co., Ltd., by its own technology, for the first time in the world. KYOWAGLAS-XA has been used in such wide fields as medical, dental, atomic power, etc. by its “easy handling” characteristic and excellent radiation shielding ability.

Features:

- Variety of lead-equivalency (selectable for different uses)
- Durability (shatter-resistance is excellent)
- Fabrication (machining, bending, and gluing are feasible)
- Transparency (light transmission is excellent with low reflection)
- Radiation-resistance (original physical property is almost thoroughly maintained after 1,000Gy exposure).



Specifications

	Lead-equivalency (mmPb ⁻¹)	Light transmission (%)	Thickness (mm)	Maximum sizes (mm)
H-8	0.3 or over	80 or over	8.5 ± 0.7	1830×2440
H-12	0.5 or over	75 or over	12.0 ± 1.0	1830×2440
H-18	0.8 or over	70 or over	18.5 ± 1.2	1830×2440
H-22	1.0 or over	65 or over	23.5 ± 1.5	1830×2440
H-35	1.5 or over	75 or over	35.0 ± 2.0	1830×2440
H-46	2.0 or over	70 or over	46.5 ± 2.5	1830×2440
H-70	3.0 or over	65 or over	70.0 ± 3.0	1220×2440



Applications

- Viewing window for x-ray room, CT room, and cardiac catheterization room
- Mobile barrier for radiation shielding
- Fixed barrier for radiation shielding
- Parts (shielding panel) for mammography and mobile x-ray equipment
- Radiation shielding booth and door for dental x-ray equipment
- X-ray compensation filter, etc.

Physical Properties

	Unit	H-12	H-35
Tensile strength JIS K7162	[MPa]	53	40
Tensile modulus JIS K7162	[MPa]	2000	1600
Elongation · JIS K7162 (Yield point · Tensile strain at tensile strength)	[%]	6	37
Flexural strength JIS K7171	[MPa]	66	64
Flexural modulus JIS K7171	[MPa]	2100	1800
Rockwell hardness JIS K7202-2	[M-scale]	88	63
Izod impact strength(Notched) JIS K7110	[KJ/m ²]	2.6	3.7
Heat deflection temperature JIS K7191-2	[°C]	71	65
Coefficient of linear thermal expansion JIS K7197	[cm/ (cm · °C)]	1×10 ⁻⁴	1×10 ⁻⁴

All data presented herein is based on measurements performed by Kuraray Co., Ltd., and other reliable information. However, the measurements are not guaranteed as they vary depending upon actual usage and conditions.

Optical Properties

	Unit	H-12	H-35
Refractive index · JIS K7142	[—]	1.55	1.55
Surface reflectivity · JIS K7375	[%]	11.2	6.7

Retention of physical properties and discoloration after exposure

	Unit	Absorbed dose	H-12	H-35
Flexural strength JIS K7171	[MPa]	0Gy	66	64
		100Gy	77	73
		500Gy	75	82
		1000Gy	78	83
Flexural modulus JIS K7171	[MPa]	0Gy	2100	1800
		100Gy	2100	2000
		500Gy	2100	2300
		1000Gy	2200	2300
Izod impact strength JIS K7110	[KJ/m ²]	0Gy	2.6	3.7
		100Gy	2.8	3.6
		500Gy	2.5	3.8
		1000Gy	2.5	3.5
Discoloration (ΔE*ab) (Hunter's color difference)		100Gy	0.6	2.5
		1000Gy	2.2	7.6





Healthcare Shielding Systems

Imaging Solutions is a leading designer, manufacturer and installer of radiation and X-ray shielding solutions in Australia.

We are part of Honey Group which specialises in the design and construction of personal radiation protection and static control walls, windows, and door sets. Imaging Solutions are also Australia's leading supplier of engineered products in lead, with a wide product portfolio covering nuclear power, nuclear medicine, X-ray, electronics, transport, defence, construction and many other industries.

As an established and well respected supplier of turn-key radiation shielding solutions to the imaging market. Imaging Solutions are one of the major installers of lead chevrons for radiotherapy bunkers and lead lined board for lower levels of radiation shielding.

We offer a total X-ray shielding solution package that includes shielding for walls, ceilings and floors. Also, lead lined door sets, lead glass observation windows and lead lined protective screens (fixed or mobile) for the following medical procedures and departments:

- X-ray
- Dental X-ray
- CT scanner
- Gamma Camera
- Fluoroscopy
- Endoscopy
- Theatres
- OPG
- Mammography
- Angiography
- Cath Labs
- Nuclear Medicine

From initial discussions, through to design, manufacture and installation, a dedicated Imaging Solutions Project Manager will work with you to ensure your shielding project is on time, within budget and to your exacting specifications.

An investment in engineering excellence underpins our commitment to providing a comprehensive service to architects, hospital trusts, building contractors and manufacturers of radiotherapy and radiology equipment. With our comprehensive range of X-ray protection products; we will continue to help protect healthcare workers and patients alike.

Why Choose Imaging Solutions?

- We have a team of highly skilled, dedicated and experienced designers, project managers and installers working to exacting quality standards
- We have an exceptional reputation for delivering what is required, within budget and on time



Chevron Rail For High Energy Radiation Shielding

The high energy X-rays used in radiotherapy and oncology demand heavy duty lead shielding

A major advantage of using lead instead of steel and concrete shielding, is that it can be quickly and cleanly assembled and just as easily disassembled when decommissioned. The lead can then be either reused in another bunker or room or sold as it is a valuable commodity.

Imaging Solutions a market leader in the design, manufacture and installation of radiation shielding for healthcare applications. Our chevron rail system is the industry standard, offering heavy duty lead shielding for high energy radiation used in radiotherapy, oncology and PET/CT facilities and brachytherapy suites.

The lead chevrons interlink to form a complete shielding solution with the elimination of any shine paths. The lead thicknesses range from 10 mm to 50 mm in lengths between 450 mm and 900 mm long and are 100 mm high. The maximum weight per chevron is 26 kg for ease of installation. Where very high energy shielding is required the chevrons can be used to create a freestanding shield structure to any required thickness.

Lead Lined Board Shielding For Lower Energy X-rays

It is very important to specify the correct thickness of lead for radiation shielding. A Radiation Protection Advisor or other shielding expert will usually do this, and when specifying the thickness of lead required where X-rays are being used for radiology and radiotherapy.

We recommend the use of British Standard BS EN 12588 rolled sheet lead. Other globally recognised sheet lead standards can be supplied on request.

If required we can provide clients with the services of totally independent professional physicist as part of our scope of supply.

When specifying the thickness of lead required to shield a facility where X-rays are being used for radiology or radiotherapy the hospitals RPA usually uses the British Standard code number (see table below)

X-ray Protective Doors

Fully customisable for radiation protection

Our doorsets are all bespoke to your specific requirements, with a range of types available:

- Single doorset – built to suit a clear opening with oversized leaves available for wheelchair or trolley access
- Double or Leaf & Half doorsets – double doors are made for openings up to 2000mm wide access
- Sliding doors – an ideal alternative to swing doors, and can be manually or automatically operated. The design allows doors to be supplied in any lead equivalence, with concealed running gear



Design and Construction

Australasia's largest turn-key range of MRI RF cage design and construction related products and services. Our single source supply offering includes site assessment, design, engineering, construction, project planning /management, compliance testing and certification and accessories.



See our Design and Construction catalogue for our full range of installation capabilities.

RADsafe Education Resources

RADsafe is a company that specializes in providing personal radiation protection solutions. Our educational resources aim to provide a better understanding of our products and how they can help protect against radiation exposure. We offer a variety of resources, such as our Size Variability Protection Zone and evaluations of our core solutions, as well as technical summaries of our core materials. Additionally, we have published articles on the importance of personal radiation protection and the benefits of our products.

RADsafe Size Variability Protection Zone

RADsafe rigorously adheres to radiation protection best practice as well as the underlying standards and guidelines. There can easily be confusion when purchasing a lead apron as how the front and back protection are achieved and how are they stated. The latest standards indicate the minimum lead equivalence across the front section of a radiation protection garment which is defined as the front sixty percent of the designed size is in fact the maximum lead equivalence allowed to be stated on the label.

Complying this the latest standards and best practice, RADsafe garments follow the below design rules:

- **Scenario 1)** RADsafe garments which have a single panel making up the front 60% or the rear 40% have the stated lead equivalence inside that single panel.
- **Scenario 2)** RADsafe garments which have two panels partially overlapping have the stated lead equivalence in each panel, this means that the overlap is twice the stated lead equivalence.
- **Scenario 3)** RADsafe garments which have two panels completely overlapping will have half the stated lead equivalence in each panel, this means that the overlap is the stated lead equivalence.

There exists a challenge in full overlap garments in that if the garment is worn incorrectly or the wrong size is worn, there could exist a scenario where the panels do not completely overlap therefore only provide half the state lead equivalence and below required protection for the wearer, due to this potential risk and our commitment to best practice protection, all completely overlapping RADsafe garments feature a "Size Variability Protection Zone".

Size Variability Protection Zone provides the wearer peace of mind in that at either edge of the overlap the garment features additional protective material reflecting the stated lead equivalence, this is approximately 10cm wide or equivalent to the size differential.

Scenario 1

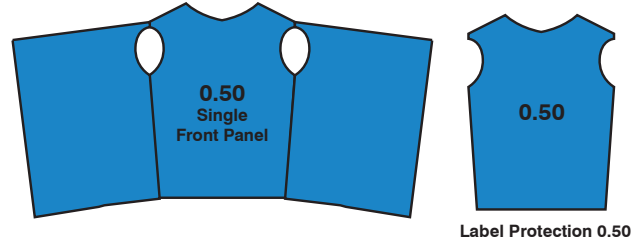

Scenario 2

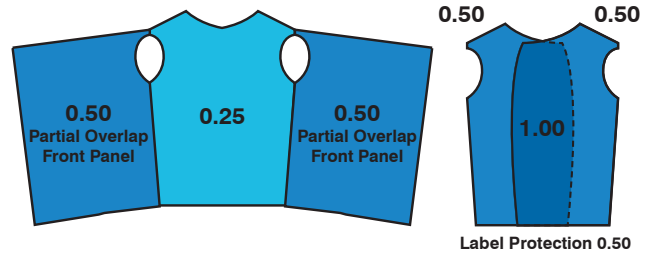

Scenario 3

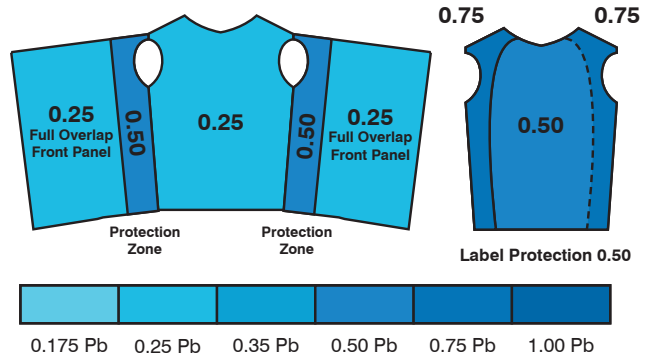

For example, if the user is wearing a 0.35mmPb front and 0.25mmPb back full overlap skirt which requires two front overlapping lapels (two panels of 0.175mmPb), if these panels were not completely overlapping then a small portion of the users front body would be only protected by 0.175mmPb below the absolutely minimum of 0.25mmPb recommend by most standards! With the Size Variability Protection Zone this scenario is prevented.

We also feature a Size Variability Indication Zone on our partial overlapping garments to provide the wearer and indication they have achieved a suitable partial overlap or if an alternative size would be more appropriate.

Evaluating your core solutions

Introduction

Understanding and reviewing your personal radiation protection has never been more important since the introduction of the latest IEC standard being IEC 61331:2014 and ASTM2547-18 (2018). These latest standards introduced a range of measures to address protection and market shortcomings. The primary changes between the latest standards include the testing methodology to determine the radiation attenuation of core materials as well as various design elements such as what determines the labelled front lead equivalency.

To illustrate the differences in the determination of the radiation attenuation of core material we will compare our latest generation RADsafe Optima and Assure core material to RADsafe Lite which reflects previous generation performance and weight. Extending on this we will then look at options that could be considered to improve your protection while minimising changes to the overall weight of the garment.

General Summary of Core Materials

RADsafe Optima and Assure are compliant to the latest and best practice IEC and ASTM standards being IEC 61331-1:2014 and ASTM2547-18 (2018). Improving on the previous generation these standards introduced a new testing method (broad beam and/or equivalent) and labelling guidelines that better reflect the real-world use and performance of core materials in a personal protective equipment context. Specifically, the latest broad beam testing method enabled the identification of previously unaccounted for secondary radiation. How these the core materials were then certified changed to reflect the different procedures and environments and in which the personal protective equipment is used. The result of these changes enabled the development of core materials that provided a wider range and more consistent radiation attenuation, to achieve this additional and differing radiation attenuating elements were required which unfortunately adversely increased the weight.

RADsafe Lite is a single layer non-lead radiation attenuating core material, providing previous generation compliance, technology, performance, and lower weight when compared to RADsafe Optima and Assure.

RADsafe Lite is compliant to the previous IEC 61331-1:1994 and ASTM2548-06 (2006) standards, the testing method within these standards is termed narrow beam. Given the compliance to previous standards it is only available in regions where these standards are accepted and where weight is prioritised over radiation attenuation. While we recommend the latest generation and best practice of protection offered by RADsafe Optima and Assure for every customer in every region, RADsafe recognises that some regions are still transitioning.

Latest and Best Practice Core Materials and Standards

The latest generation of lightweight core materials such as RADsafe Optima achieve compliance to the latest standards while optimising radiation attenuation to weight ratio using a balanced combination of low-Z and high-Z elements.

Low-Z elements, for example antimony, provide a high attenuation to weight ratio however this protection is only sustainable within a narrow radiation energy range, also as the radiation interacts with the low-Z elements, additional radiation is created in the form of scatter radiation and secondary radiation (fluorescents). High-Z elements, for example bismuth, provide a radiation attenuation to performance similar to lead itself, extending on this the radiation attenuation across relevant energy ranges is very consistent and sometimes could be termed "lead-like".

Consistency across an energy range is important requirement of the latest standards in addition to the broad beam testing method, the latest standards require core materials to achieve a radiation attenuation across an energy range that resembles the various environments personal protective equipment is used, for example RADsafe Optima is compliant from 50-110kV while RADsafe Assure is compliant from 50-150kV.

High-Z elements when mixed in with and especially when layered with low-Z elements can offset the secondary radiation, inconsistency across the energy range and harness the improved radiation attenuation to weight ratio of the low-Z elements.

Previous Generation Core Materials and Standards

The previous generation of core material that demonstrate ultra-lightweight properties such as RADsafe Lite use exclusively or high concentrations of low-Z elements. While the material is compliant with the previous generation of standards, its radiation attenuation performance is limited to the positives and negatives of the low-Z elements which is highlighted when testing these materials to the latest standards. The previous standard also only requires the core materials to be labelled and tested at a single energy point rather than a range, this hinders the user and the facility in understanding the true and real-world performance of these materials in any given environment, for example RADsafe Lite is complaint to 100kV.

When using ultra-lightweight core materials there are some key questions that need to be addressed:

- What is the radiation protection, i.e. lead equivalency, being achieved materials are tested to the latest standard?
- Extending on this, how does this protection differ at different energy levels?

Technical Summary of Core Materials

Illustrating the difference between the latest and previous generation testing methods and materials, we have provided the product, weight and compliance specifications for 0.25mmPb LE of RADsafe Optima, RADsafe Assure and RADsafe Lite below and to the right provided the attenuation performance in tabular and graph formats.

RADsafe Optima – 0.25mmPb LE @ 50-110kV, 2.90kg/m2 typical – bilayer comprising antimony and bismuth, complaint to IEC 61331-1:2014

RADsafe Assure – 0.25mmPb LE @ 50-150kV, 3.08kg/m2 typical – bismuth only, complaint to IEC 61331-1:2014

RADsafe Lite – 0.25mmPb LE @ 100kV, 2.60kg/m2 typical – antimony only, complaint to IEC 61331-1:1994

Standards Based Review of Core Material Performance

Effects of the use of Low-Z, High-Z and a combination of both are clearly demonstrated in the attenuation performance.

RADsafe Lite – it is evident that while Lite claims compliance to the previous standards, when test under the latest standard its actual radiation attenuation is approximately 40% less, this is because the old standard did not detect the secondary radiation immitted from the low-Z, antimony material. It is also notable that the core material shows much greater variation in radiation attenuation performance across the energy range which exacerbates the performance concerns if the material is used at energy ranges other than what is labelled. This core material is 15% less weight than RADsafe Optima yet when tested to the latest standards offers 40% less performance!

RADsafe Assure – it is evident that using only high-Z material, in this case bismuth only, provides the most consistent protection, this core material showed minimal variation when tested across the energy ranges across both standards. Unfortunately, this material does come with a significant weight cost being 7% heavier than RADsafe Optima and 19% heavier than RADsafe Lite. This material is perfect for use in high intensity environments, where weight is not a major concern or where “assured” protection is required, for example in-room CT assist procedures, patient protection, drapes, shielding applications.

RADsafe Optima – it is evident that using a balanced combination of low-Z and high-Z elements enables a core material to meet required performance, consistency while optimising the ergonomics, RADsafe Optima is perfect for radiation personal protective equipment.

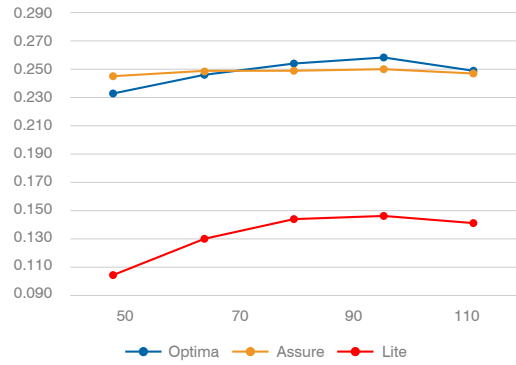

Latest Standards - Broad beam

kV	Optima	Assure	Lite
50	0.233	0.245	0.104
60	0.247	0.247	0.130
70	0.253	0.248	0.144
80	--	--	--
90	0.258	0.250	0.146
100	--	--	--
110	0.249	0.247	0.141
120	--	--	--
150	--	0.247	--

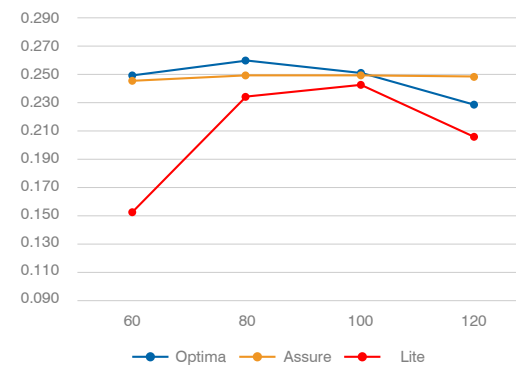

Previous Standards - Narrow beam

kV	Optima	Assure	Lite
50	--	--	--
60	0.250	0.246	0.153
70	--	--	--
80	0.260	0.250	0.234
90	--	--	--
100	0.251	0.250	0.243
110	--	--	--
120	0.229	0.249	0.206
150	--	0.248	--

Comparable Protection

Given the significant deficiencies in the protection performance of the old standard core material, RADsafe Lite, under new standard test conditions, an opportunity exists to leverage the new standard when transitioning from old standard material to maintain or even potentially reduce the overall weight of a garment while achieving comparable lead equivalent protection, more consistent protection and wider protection coverage. This is especially applicable where old standard garments feature 0.50mmPb LE front protection.

Under the new standards, specifically IEC 61331-3:2014 a 0.35mmPb front protection apron is classified as a heavy duty apron which means it can be used in high intensity, high volume settings such as cardiac catheterisation or angiography procedures, compared to 0.25mmPb which is classified as a light duty apron and can only be used in low intensity and low volume settings such as general X-Ray or theatres (these examples and references are provided as a guide only, please consult your radiation safety officer or medical physicist for your applicable requirements).

Given this information, what if you replaced your personal radiation protection featuring old standard core material, RADsafe Lite, labelled at 0.50mmPb LE with a weight of approximately 5.2kg/m², with new standard core, RADsafe Optima, labelled 0.35mmPb LE with a weight of approximately 4.00kg/m²?

You maintain similar protection as illustrated below, the personal radiation protection maintains its classification as a heavy duty apron, the protection is more consistent across the energy range while the materials direct weight required to achieve this protection is approximately 23% less!

While this weight saving is notable, it may only represent a portion of the overall garment, further to this the design requirements of the latest standards detailed in the next section.

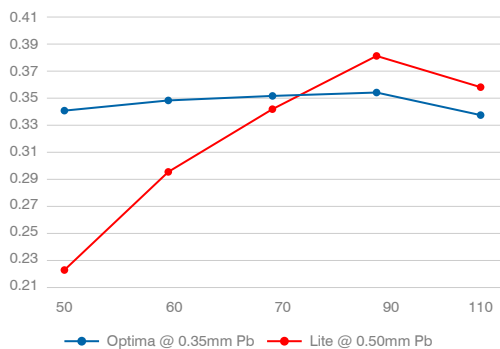

Latest Standards - Broad beam

kV	Optima @ 0.35mmPb	Lite @ 0.50 mmPb
50	0.341	0.223
60	0.349	0.296
70	0.352	0.342
80	--	-
90	0.354	0.382
100	--	--
110	0.338	0.359
120	--	--
150	--	--

Design Requirements

The new standards also made several changes to the design requirements for personal radiation protection, notably how the front and back protection is determined and labelled. IEC 61331-3:2014 specifies that the front labelled lead equivalency must be equal to the minimum lead equivalency across the front 60% of the apron.

What this means is that if a garment is labelled 0.50mmPb LE then the minimum lead equivalent protection across the front 60% of the apron must be 0.50mmPb

This is in stark comparison to the previous generation of standards that did not specify what was considered the front or back. Labelled front protection may have been labelled based on an overlapping section that might be anywhere from 30-50% of the apron potentially leaving vulnerable tissues on either side of the overlap such as breast tissues less protected.

Please see RADsafe's overlap guide for an expanded discussions and examples.

Overall this change increased the protection coverage which also increases the weight approximately 5-15% depending on the size and style of the garment.

Performance and Weight

Potential weight savings have been identified when transitioning from old standard core material to new standard core material while potential weight costs have also been identified in design requirements.

Combining these an old standard 0.50mmPb LE garment will be of negligible difference to a new standard 0.35mmPb LE garment however the new standard garment will provide comparable lead equivalent protection, more consistent protection and wider protection coverage.

Inevitable Conclusion

RADsafe personal radiation protection designs are compliant to IEC 61331-3:2014 and its RADsafe Optima and Assure are compliant to IEC 61331-1:2014, these form our CE certifications as a result of an external audit process by an EU notified body. RADsafe only recommends its RADsafe Optima and Assure ranges but again recognises that RADsafe Lite may be preferred where weight is the most critical factor and where local regulations allow it to be used in radiation environments. RADsafe Lite radiation protection will not attract CE marking given its performance reflects superceeded standards.

It is important to ensure when reviewing your personal radiation protection options, you consider the various standards and what it means for your protection and ergonomics, RADsafe personal radiation garments compliant with the latest standards are designed and certificated to provide you only the best in practice solutions

The information contained within this review further reinforces conclusions in RADsafe's "Understand Lead Aprons" series, any reduction in weight from the benchmark lead rubber (approx. 3.50kg/m²) must sacrifice protective qualities, weight equals protection, the physics can't be broken.

Weighing In On Personal Radiation Protection

Dr. Johnny Laban PhD

Radiation physics consultant to RADsafe

The protective garment or “lead apron” is a critically important item for the protection of staff involved in work where fixed physical barriers are not available or feasible to shield radiation scattered from x-ray equipment or patients. The detrimental effects of x-ray radiation are well understood, and the need for good quality aprons that provide sufficient levels of protection for the work being undertaken is not disputed by anyone. Further, the use of radiation in almost all applications is tightly controlled by local regulatory authorities, but despite this, it is a remarkable fact that in most of the world, Australasia included, the claims apron manufacturers make, and the labelling they fix to their garments often does not give an accurate picture of the apron’s true protective abilities.

This article is the first of a series to be published over the next few issues of Spectrum that will focus on the lead aprons used by staff in diagnostic imaging and interventional procedures, and the factors that have contributed to the situation mentioned above. The intention of these articles is to provide interested readers an insight into what aprons are made of, how they work, what the metrics of protection are and how they are measured, and most importantly, how to interpret the marketing information provided by manufacturers and suppliers engaged in the business of selling aprons. People required to make lead apron purchasing decisions will hopefully find these articles helpful, as will anyone who is curious as to why two aprons of the same size and with the same claimed level of protection can weigh substantially different amounts.

Weight Vs Protection

Naturally there is a demand from the market for lightweight protective garments because weight is a very significant contributor to overall comfort. Modern medical practices often involve complex and long procedures, requiring aprons to be worn for extended periods of time, and fatigue or injury are very real issues for wearers.

Unfortunately, it is unavoidable that adequate attenuation of diagnostic x-ray radiation requires a significant mass of material and so protection, and wearing comfort are somewhat in competition with each other. A compromise needs to be made whereby an adequate level of protection is provided, and the wearer afforded good quality of working life.

Apron manufacturers have responded to this challenge in the last several decades by producing aprons that use materials other than lead as their key attenuating agent. The accepted testing laboratory measurement methods available to determine the attenuating ability of aprons have not been truly representative of actual exposure situations for wearers though. As a result, the market is full of non-lead or reduced-lead aprons with weights significantly less than the weight of the equivalently labeled lead based garment. Often, these claims are quite inaccurate in terms of actual protection.

This is not to say that manufacturers are deliberately misleading their customers. Rather, a shortcoming in testing methods has existed that has provided the so-called lightweight non-lead garments an apparent advantage. The situation has begun to change with the recent publication of new measurement methods

for testing laboratories to follow. These methods give more representative measures of the attenuating ability of a nonlead apron when compared to a lead apron, and so a more accurate picture is beginning to emerge. A consequence of these changes will not necessarily be that apron weights will increase. Instead, it is hoped that the labelling fixed to aprons to indicate their protective abilities will be a more accurate reflection of reality. Unfortunately, it takes some time for new standards and methods to be adopted, and in the meantime, manufacturers will continue to seek an “edge” by making statements based on results obtained using the older standards.

Evolution of the Apron

As mentioned, the lead apron has evolved considerably in the last century. Regardless of the construction particulars, all aprons rely on the same radiation interaction mechanisms to achieve their attenuating abilities, and these mechanisms require the use of high atomic number elements.

Conventional textiles used for garment manufacture do not contain high atomic number elements, and so some means is required to incorporate these elements into suitably flexible and workable substrate materials.

Historically, the substrate material used was rubber, and lead has been the preferred attenuating element because it has a high atomic number, exists as a stable pure metal, and does not react with other materials. It can be readily powdered to a fine particle size, and in this form can be mixed into the uncured rubber. Once cured, a flexible sheet of attenuating core material is obtained that can be cut into patterns and stitched into garments. Early aprons materials were not particularly flexible, and styles were limited to “front and back over-the-shoulder drapes”. More recently synthetic rubbers, and PVC vinyls have been employed, and these materials can be cast into thinner layers, affording more flexibility. This has allowed for the option to manufacture actual fitted vests with companion skirts as a means of providing full protection to the human trunk, but with the advantage that weight is distributed to the shoulders and the hips.

“

Elements such as tin, antimony, barium, and bismuth are the most commonly employed today.

”

Other elements with moderate to high atomic numbers have become popular as attenuating materials. In addition to lead, elements such as tin, antimony, barium, and bismuth are the most commonly employed today. The primary driver for their use has been to offer apparent weight advantages, but concerns about the health and environmental impacts of lead have also motivated the use of these other elements.

The evolution of the “lead apron” is shown in the images 1-3, which covers a time span of approximately one century. In some regards, it would be fair to say nothing much has changed, whilst in others, a number of innovations have taken place.

WeighingInOnPRP RADsafe® personal radiation protective apparel and eye wear is setting new standards in innovative and reliable protection for healthcare professionals around the world.

Image 1 of a protected worker has been obtained from material provided by the International Atomic Energy Agency (the IAEA), and is dated 1916. Note the obvious inflexibility of the apron material, which almost looks like it could have been constructed from straight lead sheeting.

The garment modelled in image 2 is typical of what was available in the 1970s. The core material is lead rubber based. Despite the apron covering both front and rear, note the gapping areas at the sides potentially exposing sensitive tissues to unattenuated radiation.

The garment in image 3 is representative of products available today. Its core material may be either synthetic rubber, or PVC (vinyl) based, and will utilise either lead, reduced-lead, or non-lead based materials to attenuate the radiation. Note the vest/skirt configuration employed to distribute weight to both the shoulders and the hips, and the snug fit under the arms to ensure completed protection of the trunk

This article has served as an introduction to the humble lead apron, and has touched upon a range of topics that in the forthcoming issues of Spectrum will be expanded upon. Real world measurement data and diagrams will be used to explain how the measurement standards work, and most importantly, what to look for when navigating the critical issue of weight vs protection in selecting suitable lead aprons.



Getting “Physical”

This second article in the “lead apron” series will focus on the underlying physics concepts that are relevant to protective garment performance. To understand what differentiates the performance characteristics of one protective garment from another it is necessary to understand how the materials incorporated within the apron attenuate the x-ray radiation. So, although this article will delve into the more technical aspects of lead aprons (please refer to the glossary at the end of the article for explanation of the terms and units used), understanding the underlying concepts will be useful in assisting you when interpreting the labelling and marketing material associated with them.

When diagnostic x-ray radiation passes through a medium, the two key interaction processes that can occur are Compton scattering and photo-electric absorption.

Compton scattering is depicted in Figure 1 and occurs when the energy of the x-ray photons is significantly higher than the energy that binds electrons to an atom. In a Compton interaction, the incoming x-ray photon will scatter off a loosely bound electron, and continue on in some direction with a diminished amount of the energy until it undergoes further interactions, or leaves the medium. The energy lost by the photon is imparted to the ejected electron as kinetic energy.

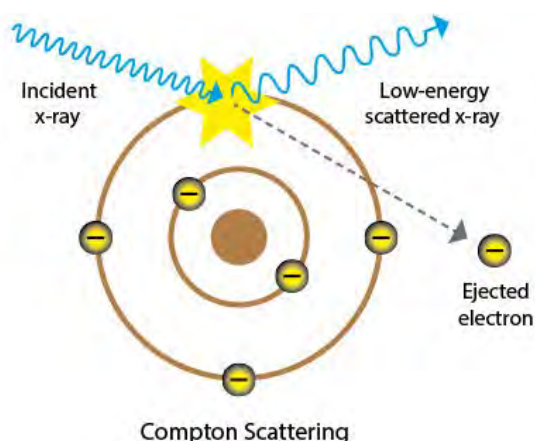

Fig1. - Schematic diagram of Compton scattering

The photo-electric interaction is depicted in Figure 2 and occurs when the energy of the x-ray photons is just above the binding energy of electrons in an atom. In a photo-electric interaction, the incoming x-ray photon is completely absorbed, and ejects a tightly bound inner shell electron from the atom. The atom's other electrons will then redistribute themselves, resulting in the emission of fluorescence x-rays in a high proportion of cases. As for the Compton scattered x-ray, the fluorescent x-ray will then undergo further interactions, or leave the medium.

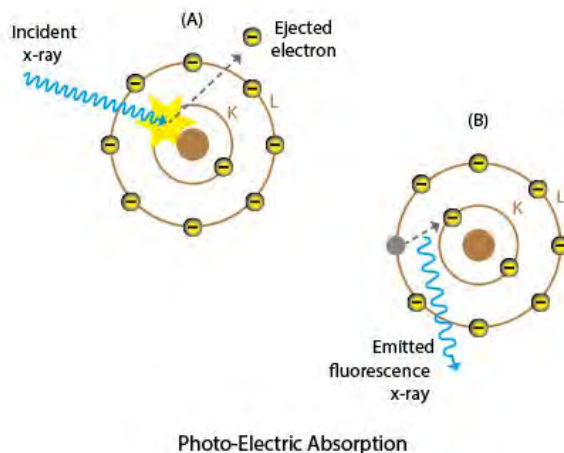

Fig2. - Schematic diagram of photo-electric absorption, and subsequent fluorescent x-ray emission

In the context of diagnostic imaging, soft tissue is comprised mainly of the low atomic number elements hydrogen, carbon, and oxygen (atomic numbers 1, 6, and 8 respectively). The electron binding energies for these light elements is low, and so the Compton interaction dominates when diagnostic x-rays pass through soft tissue. In conventional radiography and fluoroscopy, the Compton interaction is of little benefit – it deposits dose in the patient, and the Compton scattered photons that exit the patient and reach the image receptor reduce image contrast.

In bone, the presence of significant amounts of phosphorous and calcium (atomic numbers 15 and 20) means that photo-electric patient and reach the image receptor reduce image contrast.

In bone, the presence of significant amounts of phosphorous and calcium (atomic numbers 15 and 20) means that photo-electric interactions dominate over Compton interactions. This is the reason x-rays can be used to delineate bone within soft tissue – the combination of higher density, and higher atomic number means the bone absorbs and scatters more radiation, and effectively casts a “shadow” on the image receptor.

Before looking at what role these interaction processes play in protective garments, it is important to understand the main metric that is used to describe the protective ability of a lead apron. The metric is known as lead equivalence. For a particular material, its lead equivalence can be defined as the thickness of pure lead that is required to produce the same measured ratio of attenuation of an incident radiation beam as the test material. Figure 3 illustrates this point.

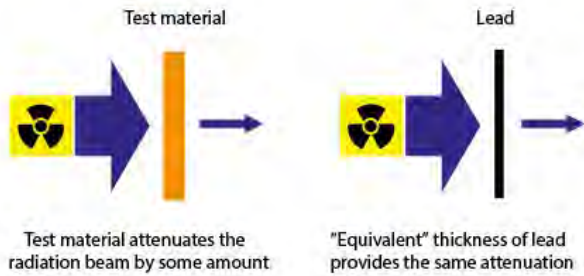

Fig3. - Schematic representation of lead equivalence determination

There is some discussion concerning the merit of lead equivalence as a metric for protection. Its use traces back to the historical use of lead in garments, but there is nothing intrinsically special about lead beyond this. Lead equivalence does provide a simple index that most people in the industry are familiar with. It is widely recognised that in round terms, an apron with a lead equivalence of 0.25 mm Pb is suitable for lower energy radiation sources, and light duty use. For higher workloads or x-ray energies, a 0.35 mm Pb, or even 0.50 mm Pb apron will afford the appropriate amount of protection. In this regard, it is a simple and convenient measure, even if the actual lead equivalence doesn't provide explicit information about the level of protection. The process of measuring lead equivalence and relating this to actual wearing conditions is a topic in its own right, and the methods used will be discussed in the next apron article.

Returning to aprons, the photo-electric interaction probability increases sharply as the atomic number of the element increases, and so in terms of providing the most effective attenuation, the high atomic number elements are the best. Compton scattering will occur off the substrate PVC or rubber materials used in the apron's construction, but the photo-electric interactions with the heavy elements will dominate by several orders of magnitude. Historically, lead (atomic number 82) has been the preferred material. The reasons for this were mentioned in the first Understanding lead aprons article, namely that it is plentiful and cheap, has a high atomic number, exists as a stable pure metal which can be readily powdered, and does not react with other materials. Concerns over the environmental effects of improper disposal of lead based products, and the possibility of achieving better performance for a given weight in some circumstances mean that medium atomic number elements such as tin, antimony, barium, and tungsten are now popular as the attenuating agents in lead aprons.

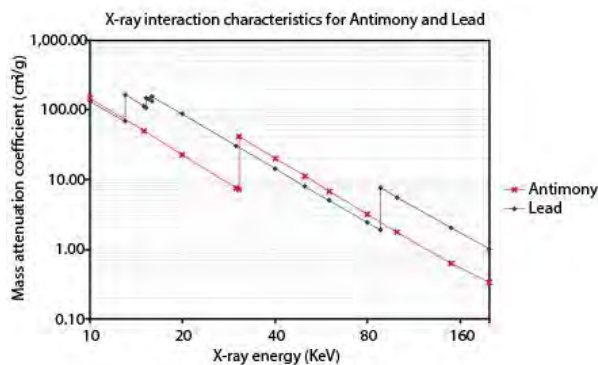

Fig4. - Mass attenuation coefficients for antimony and lead for x-ray energies from 20 to 160 keV

To understand how the lead equivalence of the non lead materials used in an apron will behave, a plot of the absorption characteristics of lead, and antimony over the diagnostic x-ray energy range is shown below. The lines plotted in Figure 4 show what is known as the mass attenuation coefficients for the two materials. Put simply, the mass attenuation coefficient provides a measure of the interaction probability as an x-ray passes through a unit thickness of the given material. Mass attenuation data is published by the US National Institute of Standards and Technology on their website at <http://physics.nist.gov/PhysRefData/XrayMassCoef/tab3.html>.

It can be seen that for both elements there is a general downward trend as the energy of the x-rays increases. In other words, as the x-ray energy increases the x-rays become more penetrating. The discontinuities that occur at around 15 keV and at 88 keV for lead represent the transitions where the x-ray energy matches the binding energy of the inner most shells of electrons (in this case the L and K shells respectively), so that photo-electric interactions are suddenly far more likely to occur. In the case of antimony, the K-shell discontinuity occurs at 30 keV – considerably below the 88 keV of lead due to its lower atomic number (51 compared to 82). These features combine to provide three distinct regions of interest in terms of lead equivalence – the one below 30 keV where the mass attenuation coefficient of lead is greater than antimony, the region between 30 keV and 88 keV where the antimony is greater, and above 88 keV where lead is greater again.

From the point of view of protection, if the bulk of the x-ray spectrum sits in the region between 30 and 88 keV, then elements like antimony offer the possibility of providing better attenuation for the same mass of material. Conversely, if the spectrum moves significantly to the left (lower kV), or right (higher kV), then lead offers better performance. It follows that this behaviour with x-ray energy will be reflected in the lead equivalence results as the energy of the test x-ray beam is varied.

An example of some lead equivalence measurement data is shown in the plot on Figure 5 for a non lead garment with a stated lead equivalence of "0.50 mm Pb". Consistent with the discussion above, it can be seen that the maximum lead equivalence of 0.50 mm occurs for an x-ray tube voltage of around 90 kV, and drops either side of this as the x-ray spectrum covers more of the region outside the 30 – 88 keV range.

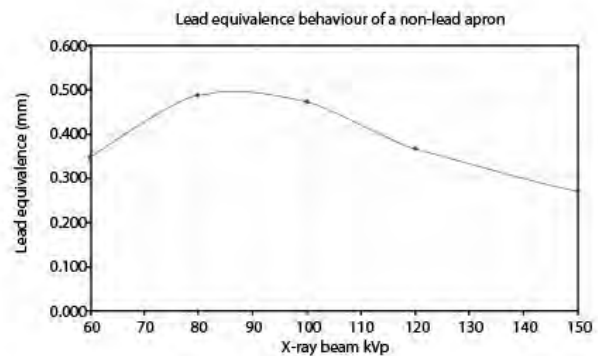

Fig5. - The behaviour of lead equivalence as a function of x-ray tube voltage for a non-lead based garment

Given that lead equivalence behaves in this general way for all non lead or low-lead garments, when considering what apron is appropriate for a given task, it is important to understand what the lead equivalence is over the entire range of energies likely to be encountered. For example, in interventional and fluoroscopic procedures, the primary source of radiation exposure to an operator is from patient scatter, and given the typical kVs used, the nonlead garments can provide a good level of protection for their weight. If the energies being encountered are higher, for example, in cases such as an “in-room CT-assist” procedure, or nuclear medicine procedure involving Tc-99m, then a lead apron is more likely to offer better protection for a given weight since its lead equivalence remains constant.

Ideally, the garment labelling should provide a clear statement of the lead equivalence, and over what range of kVs it is applicable. In a lot of cases, only the peak lead equivalence value is provided, and perhaps the kV at which it was measured. This leaves the prospective purchaser with no useful information about what happens at other energies. New standards that have been published are more prescriptive around labelling requirements, and this will hopefully improve the situation in time. In the meantime, if there is any doubt about interpreting the labelled lead equivalence of an apron, then advice should be sought from a radiation protection officer, or medical physicist.

Glossary of Terms

Binding energy – the energy that is required to separate an electron from its parent atom.

Electron shells – the electrons within an atom are arranged in shells like the layers of an onion. The inner most shell of electrons has the highest binding energy, with each shell further out having a progressively reduced binding energy.

keV – kiloelectron-volt. The electron-volt is a unit of energy commonly used when describing the energy of x-rays and electron binding energies. An x-ray tube connected to a generator with its kilovoltage set to 80 kV will produce a spectrum of x-rays with energies up to 80 keV. At 100 kV, x-rays with energies up to 100 keV are produced, and so on.



Setting The Standards

In the previous Understanding lead aprons article, the concept of lead equivalence was introduced, and it was shown how the different materials that are used to attenuate the x-ray radiation in a “lead apron” can affect the lead equivalence. In this article the measurement methods used to determine lead equivalence and the effect that these methods can also have on the results obtained will be scrutinised. The measurement methods followed are prescribed in several international standards related to protective garments and equipment, and whilst details of these methods will be of limited interest to readers, there are several key messages concerning lead equivalence that emerge from the details, and should be noted.

To recap from last month’s article, the lead equivalence of a protective garment can be defined as the thickness of pure lead that is required to produce the same measured ratio of attenuation of an incident radiation beam as the test material. What is not stated in this definition though, is how the measurement is performed.

In terms of the measurement set-up, there are two categories of measurement geometry: narrow beam, and broad beam. In a narrow beam set-up, the detector is placed some distance from the x-ray source – usually something like 1 m, and the x-ray beam is tightly collimated (or coned-in) to an area of only a few centimetres square in the plane of the detector (hence the name “narrow beam”). The sample being tested, or lead filters being used as the reference are placed approximately half way between the x-ray source, and the detector. This geometry is shown schematically in Figure 1 below.

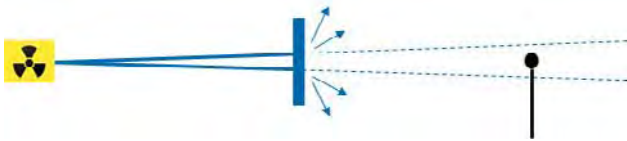

Fig1. - Narrow beam attenuation measurement geometry

The photo-electric interaction process which is responsible for the attenuation of radiation in the apron material also produces fluorescence x-rays. These are emitted in all directions within the apron material, and whilst the majority are re-absorbed in the material a proportion of them will escape the exit side of the material. The narrow beam measurement geometry is designed to measure only the transmitted primary beam and not the fluorescence x-ray scatter produced.

Considering that an apron is worn close to the body, and so the wearer will be exposed to any scatter produced in addition to the transmitted primary beam, the narrow beam geometry does not give a representative measure of the lead equivalence of non-lead material. In the diagnostic x-ray energy region between 30 and 90 keV, the non-lead materials used like antimony produce significantly more fluorescence x-rays than lead, and so the narrow beam measurement geometry over estimates their lead equivalence. Clearly this is not ideal, and a more representative measure is required.

A broad beam measurement geometry will produce a more representative measure of lead equivalence. In a broad beam set-up the x-ray beam is no longer tightly collimated, and the area of radiation impinging on the sample is quite large – typically 20 – 30 cm square. The detector is placed closely behind the material. This geometry is shown schematically in Figure 2 below.

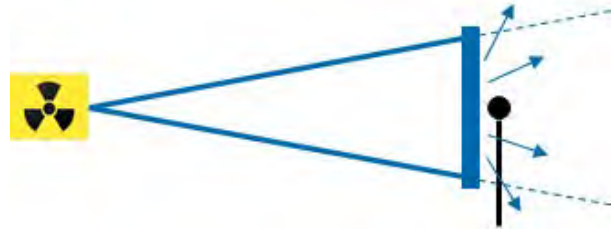

Fig2. - Broad beam attenuation measurement geometry

A broad beam measurement set-up most closely resembles the real world exposure circumstances of someone wearing an apron. Ideally then, when assessing lead equivalence of a protective material, a broad beam geometry is desirable, however, the problem has been that broad beam measurements in the laboratory are not easily reproducible between laboratories, and require large pieces of reference lead material, which are not readily available, and are difficult to handle. Recent standards have introduced an alternative measurement set-up (called inverse broad beam geometry) that over comes these problems, and produces the same results as a broad beam set-up.

In the inverse broad beam geometry the x-ray beam remains tightly collimated, allowing the use of small reference lead filters, but the detector is placed closely behind the sample, and has a large area that intersects all of the transmitted x-ray beam. This geometry is shown below in Figure 3.

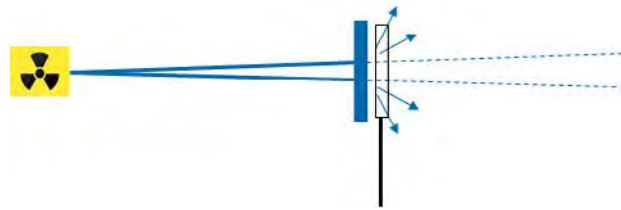

Fig3. - Inverse broad beam attenuation measurement geometry

The inverse broad beam measurement method provides results equivalent to the broad beam measurement method, and so the apron industry now has available to it a viable means of determining lead equivalence that provides a realistic comparison for the non-lead based aprons against aprons comprised predominantly of lead.

The effect of the two fundamental types of measurement – narrow beam and broad beam (achieved through the use of the inverse broad beam measurement method) – can be seen in Figure 4 which shows the measurement data from a popular non-lead apron with a claimed lead equivalence of “0.5 mm Pb”.

It can be seen from the graph in Figure 4 that under narrow beam measurement conditions, the apron just achieves its 0.5 mm Pb lead equivalence (and only around the 80 kV – 90 kV test point for reasons discussed in the previous “aprons” article). In contrast, under inverse broad beam measurement, the apron fails to achieve even 0.4 mm Pb, and would more accurately be described as a 0.35 mm Pb apron, and this for the range from 70 – 110 kVp.

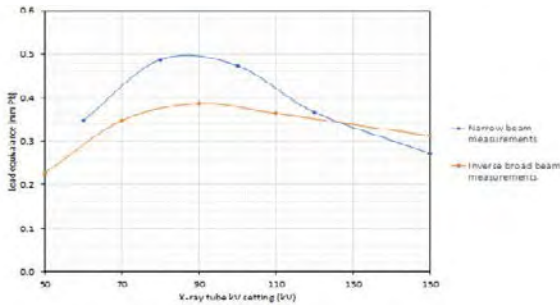

Fig4. - Comparison of lead equivalence determined using narrow- and inverse broad-beam measurement methods for a “0.5 mm Pb” non-lead based apron

The approximately 20 % reduction in peak lead equivalence under broad beam measurement conditions is typical of conventional reduced-lead, or non-lead aprons that are constructed from a homogenous mixture of elements. If the apron is constructed either totally from lead, or if it is constructed in a layered fashion, with the inner layer nearest the wearer being either lead or the element bismuth, then this behaviour will not occur. This is because the photo-electric fluorescence x-rays produced by the non-lead elements are masked by the exit layer of lead or bismuth, and the inverse broad beam measurement results should match the narrow beam ones.

So where does this leave the prospective purchaser in terms of trying to navigate their way through the issues of lead vs non-lead, and lead equivalence determined according to narrow or inverse broad beam methods?

Well, the lead equivalence behaviour of non- or reduced-lead garments, which was covered in the previous “Understanding lead aprons” article, is an intrinsic aspect of these aprons. Users simply need to be aware of this characteristic when selecting a suitable range of protective garments.

In terms the measurement method used to determine lead equivalence, there are two main standards relevant for Australia and New Zealand: AS/NZS 4543-1(1), and IEC 61331-1 (2nd ed.) (2).

AS/NZS 4543-1 is an old standard based on the first edition of IEC 61331-1, and contains only narrow beam measurement methods for lead aprons. The second edition of IEC 61331, published in 2014, requires the use of the inverse broad beam measurement methods for assessing the lead equivalence of protective garments. So, if the garment labelling indicates that lead equivalences have been determined according to either AS/NZS 4543-1, or, more likely, the first edition of IEC 61331-1 (1994), then they are narrow beam determinations. Alternatively, if the second edition of IEC 61331-1 (2014) is stated as the standard used, then inverse broad beam methods have been used. It is often the case that this information is not clear from the garment labelling in which case the best course of action will be to directly question the suppliers about the methods used behind the quoted lead equivalence values.

References

- (1) AS/NZS 4543-1: Protective devices against diagnostic medical X-radiation - Part 1: Determination of attenuation properties of materials. 1994.
- (2) IEC 61331-1 (2nd edition): Protective devices against diagnostic medical X-radiation - Part 1: Determination of attenuation properties of materials. 2014.

Facts About Protection And Weight

Introduction

The previous two Understanding Lead Aprons articles appearing in Spectrum have provided readers with background technical information to enable a good understanding of:

The types of attenuating materials used in lead aprons, and how and why their lead equivalence varies as the x-ray beam energy changes, and;

The narrow beam and inverse broad beam measurement methods used to determine lead equivalence, and the different results obtained between these methods, depending on the apron construction.

In this article, the key issue of weight versus protection for lead aprons will be scrutinised with the benefit of knowledge gained from the above, enabling some interesting facts to emerge from a wealth of sometimes misleading manufacturer's marketing claims.

The Facts On Weight And Protection

The weight of a garment is determined by three physical attributes: the type of core material used, the thickness of the core material and the surface area of the garment.

The types of core material can be loosely divided into lead based, and non- or low-lead based materials. It has been explained how results determined according to the current AS/NZS standard with the narrow beam method do not accurately reflect the true protective abilities of the non- or low-lead core materials, with their results appearing to show better protective abilities for a given mass than the lead based materials. So, what follows, core material from a range of lead aprons produced by different manufacturers has been analysed for weight, and for lead equivalence using the inverse broad beam method to enable a true comparison of weight characteristics for a given level of protection.

Lead Based Core Materials

The lead equivalence for a range of lead based materials has been determined, along with the mass per unit area of the material. These measurements have been normalised to a calculated mass per unit area corresponding to a 1 mm lead equivalence in each case, and the results are shown in figure 1 below.

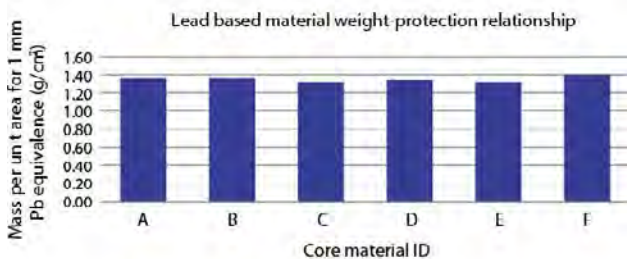

Fig1. - Normalised mass per unit area to produce 1 mm of Pb equivalence for six lead based apron materials

Within a few percent either way, a 1 mm Pb equivalence requires a material weighing on average 1.36 g/cm² (the full range observed is from 1.33 to 1.41 g/cm²). As a point of reference, pure lead has a density of 11.34 g/cm³, and so a 1 mm thickness of pure lead weighs 1.134 g/cm². The increase in weight in the core materials from this value is due to the plastisol or rubber substrate material, which necessarily adds weight, but unfortunately, very little protection.

The variations in weight observed above are due to variations in the ratios of lead powder added to the substrate material. Ideally the maximum amount of lead possible should be added to the substrate material subject to not compromising the flexibility, structural integrity, or lifespan of the final product.

Non- And Low-Lead Based Core Materials

The lead equivalence for the non- and low-lead based materials has similarly been determined, along with the mass per unit area of the material. As discussed in an earlier article, the lead equivalence of non-lead materials has an energy dependence, and the data below is taken from a series of measurements at 90 kVp. This was chosen as an energy towards the higher end of what is typically encountered in fluoroscopic procedures, and a point where adequate lead equivalence is important. These measurements have been normalised to a calculated mass per unit area corresponding to a 1 mm lead equivalence in each case, and the results are shown in Figure 2 below.

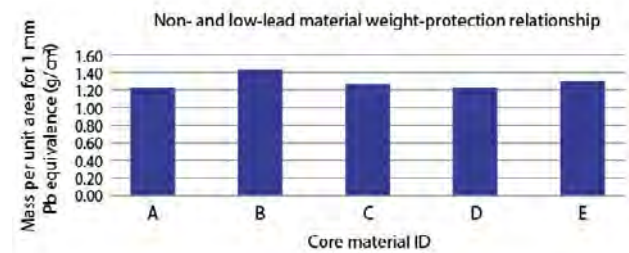

Fig2. - Normalised mass per unit area to produce 1 mm of Pb equivalence for five non- or low-lead based apron materials

Whilst there is a wider variation in the mass required to achieve 1 mm lead equivalence across the core material types, a 1 mm Pb equivalence at 90 kVp requires a material weighing on average 1.29 g/cm² (the full range observed is from 1.22 to 1.43 g/cm²).

The wider variation in the weights observed here relative to the lead based materials is due to the variety of attenuation materials in use (typically mixtures comprised from tin, antimony, barium, tungsten, lead or bismuth).

The key message from the above data is that although the non-lead materials do provide equivalent protection at 90 kV for a reduced weight, it is only a marginal reduction of about 5 % on average. Further, this is at 90 kV where the non-lead materials perform best. The data at 110 kV shows that the lead based, and non- or low-lead based are equivalent to within several percent in terms of weight for a given level of protection.

Importantly, the data shown above is for conventional non- or low-lead based materials comprised of homogenous mixtures of elements. The layered materials that are available perform better because the low energy fluorescence x-rays are blocked by the second layer of lead or bismuth. Only one brand of bi-layered material has been available to test for this work, and the results show that 1 mm of Pb equivalence can be achieved at a weight of 1.16 g/cm², which is a 15 % improvement over the lead based materials.

Garment Surface Area – Style And Fit

Putting aside the physics considerations of radiation attenuation, the weight of a garment is also directly related to the amount of material required to construct it. So, reductions in over-all weight can be achieved by, for example, increasing the gap around the armhole, or reducing the extent of overlap in a double-breasted style vest or apron, where both layers are required to achieve the stated lead equivalence, or by shortening a vest, allowing for the possibility of exposure to the waist area between the vest and the skirt. These are obviously all detectable short-comings of a garment design, and the consumer should be diligent in ensuring staff are properly fitted for the garments they are intending to wear. The possibility of exposing sensitive tissues to un-attenuated radiation as a result of poor fitting is a very real possibility, and one that should be avoided at all costs.

Consumers should also look for features like shoulder pads and specially constructed waist support belts. Together these reduce load pressures and improve both posture and the comfort of the wearer, improving the quality of working life while maintaining the required radiation protection.

Conclusions

All wearers are sensitive to the weight burden when wearing a lead apron however the clear conclusion from the data presented above is that significant differentials in apron weight are likely to represent significant variations in the protection being afforded the wearer. The only exception to this being the bi-layer materials that can offer some weight reduction for comparable protection.

A translation of this conclusion is that despite the marketing hyperbole often encountered, basic physics considerations dictate that there are no “silver bullet” materials that can offer twice the protection at half the weight.

If an apron seems surprisingly light for its claimed lead equivalence, then it should be treated with caution. The key thing to check is the pedigree of the lead equivalence testing underpinning the statements made on the garment label. The testing should be done using inverse broad beam methods employed by the more recent standards, and not the narrow beam methods described in older standards.

To prioritise weight over protective abilities is to disregard the intent of the standards and regulations currently in place in Australia and New Zealand, which are all there to set minimum acceptable levels of protection for wearers. To improve the quality of working life for apron wearers, it is strongly advised that rather than seeking to source significantly lower weight garments, products which incorporate ergonomic benefits such as shoulder pads, and built-in belts should be sought to mitigate the detrimental effects of apron weight.



Explore Our Range

At Imaging Solutions, we take pride in offering an extensive and comprehensive range of products designed to cater to the diverse needs of healthcare facilities across the globe. Our commitment to providing top-quality equipment and technology solutions is at the core of our Preferred Supplier Agreement. This ensures that our customers receive unparalleled access to the best in class products, while benefiting from the tangible value we deliver through managing and containing operational costs. With a broad spectrum of offerings, our Single Source Supply agreements are the ideal solution for meeting your facility's specific needs.

As your trusted partner, Imaging Solutions is dedicated to providing a seamless and integrated experience, allowing you to focus on delivering exceptional patient care. With our Preferred Supplier Agreement, you can have confidence that you are investing in the most advanced and reliable products in the industry, all while enjoying the cost-saving benefits that our Single Source Supply agreements provide. Explore Our Range and discover the Imaging Solutions difference.

Your Single Source Supplier™

Established initially as a small medical imaging hardcopy film and consumables distributor, specialising in analogue based imaging technology, the company very quickly identified the need for a reliable supply source of high quality imaging accessories. As a result, the business targeted a niche of premium suppliers of imaging accessories and over a short space of time acquired distribution access to develop an initial foundation for today's expansive and comprehensive accessories portfolio. These industry wide market leading brands converge to develop a comprehensive product portfolio offering the company markets today.

Effectively on completion of our initial growth phase, in building the accessories range offering, Imaging Solution set about the task of identifying the world's market leading brand, in every functional specialisation existing in the imaging market.



Radiation Protection

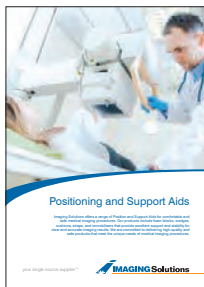

Positioning and Support Aids



Grids and Detector Accessories



MRI Equipment and Accessories



Design and Construction

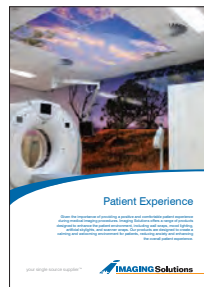

Patient Experience

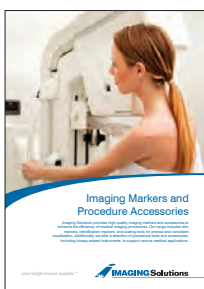

Imaging Markers and Accessories

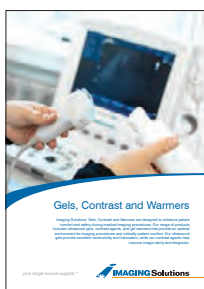

Gels, Contrast and Warmers

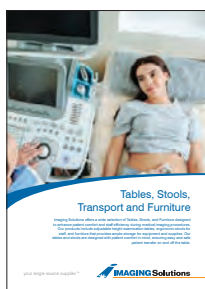

Tables, Stools, Transport and Furniture



Trolleys, Stands, Carts and Storage

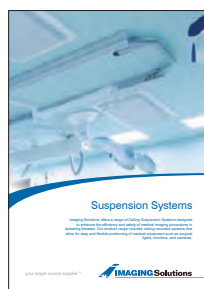

Suspension Systems

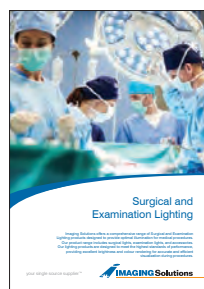

Surgical and Examination Lighting

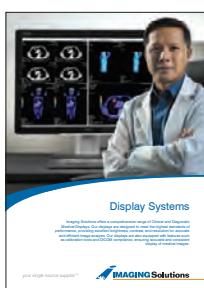

Display Systems



Data Management



Healthcare IT



Phantoms



your single source supplier™

your single source supplier™

Global / Online

www.imgsol.com
info@imgsol.com
+61 7 3387 0400

Australia

PO Box 3225
Loganholme, QLD, 4129
Australia
1300 132 100

New Zealand

PO Box 113098
Newmarket, Auckland
New Zealand
0800 723 776

United States

222 W. Las Colinas Blvd, Suite 1650E
Irving, TX, 75039
USA
(866) 586-0915

Europe

25 Bd Romain Rolland,
92120 Montrouge
France
+33 6 5262 3244

